

MADE IN

U. S. A.



FOREST INDUSTRY



CHAINS · SPROCKETS · VIBRATING CONVEYORS

ENGINEERED TO EXCEL



ABOUT US

Webster Industries, Inc., headquartered in Tiffin, Ohio, is an innovative leader in the engineered class chain, sprocket, vibrating conveyor and malleable cast iron markets. Since its start in 1876, Webster has evolved into a vertically integrated chain manufacturer that serves a variety of industries. The company now employs around 300 people nationwide and has facilities in Ohio, Mississippi and Oregon. Throughout its 140 years in business, Webster's focus has consistently been on American materials, American labor and American pride. A strong concentration on customer service, based on seamless vertical integration ensures that Webster's clients receive the highest quality products and service in the industry.



VERTICAL INTEGRATION

While many companies rely increasingly on outsourcing for production needs, Webster Industries has invested in building, maintaining and growing a vertically integrated manufacturing system. With full services under one roof at our Tiffin, Ohio, headquarters, Webster offers superior product design, consistent product quality and the best delivery time in the industry. Our 350,000 square foot manufacturing facility includes the following departments:

- Punching & Stamping
- Heat Treat
- Machining & Sprocket Fabrication
- Metal Fabrication
- Chain Assembly & Welding
- Foundry

OUR PRODUCTS



**ENGINEERED
CLASS CHAINS**



SPROCKETS

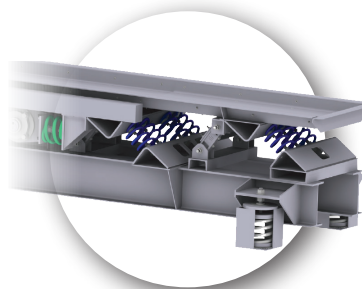

**VIBRATING
CONVEYORS**

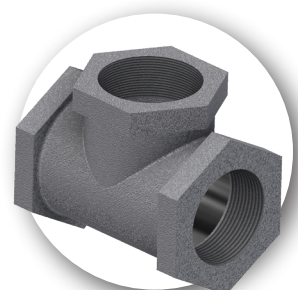

**SPECIALTY
CASTINGS**



WEBSTER'S MANUFACTURING PROCESSES

Webster Industries utilizes a variety of manufacturing processes to ensure the highest quality solution is delivered to our customers. Webster's burnished holes and induction hardening are two of those value-added processes.

THE BEST HOLE IN THE INDUSTRY

Burnishing is a unique cold-forming process where a graduated mandrel (punch) is used to punch the sidebar pitch holes. First, the punch pierces the sidebar material, producing a heavy tapered slug. The punch rubs the metal surface of the pitch hole with sufficient force to cause plastic flowing of the metal. This rubbing or smearing (burnishing) action of the metal fills the breakout or tapered portion of the hole that was produced during the initial piercing operation. Single punched holes, as shown in Figure 1.1 below, only allow for 15-20% bearing surface. Punch & shaved holes, as shown in Figure 1.2 below, allow for 60-75% bearing surface. Webster's burnished holes achieve 85-90% bearing surface, as shown in Figure 1.3. Compared to single punched holes, burnished holes allow at least five times more surface against which the pin can rest, resulting in minimized material deformation of the hole under heavy loads.

The burnishing process results in a high quality, tighter tolerance, fatigue resistant, work hardened side bar holes, which are all primary keys to extend chain life. The major advantages of burnished pitch holes are the amount of bearing surface, accuracy of hole size and consistency of press fit.

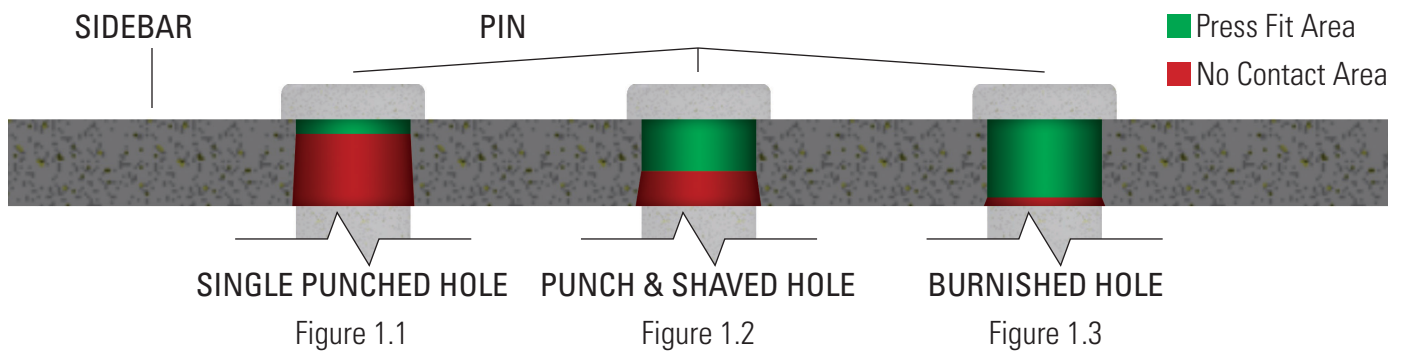

THE BEST PIN IN THE INDUSTRY

Induction hardening is a non-contact heating process that utilizes the principle of electromagnetic induction to produce heat inside the surface layer of a workpiece. By placing a conductive material (pin) into a strong alternating magnetic field (coil), electrical current can be made to flow in the material, creating heat. The current generated flows predominantly in the surface layer of the part; the depth of the hardened layer is determined by the frequency of the alternating field, the surface density and permeability of the material, the heat time, and the pin diameter or material thickness. Then, by immersing the part in a water, oil or polymer-based quench, the surface layer is altered to form a martensitic structure which is harder than the base metal. The core of the material remains the same, and its original properties are unaffected by the induction hardening process.

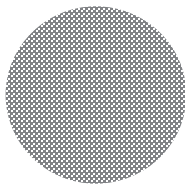

WEBSTER THRU-HARDENED PINS

Webster's pins are made of Duralloy®, thru-hardened to 35/40 Rc where the diameter is less than 3/4".

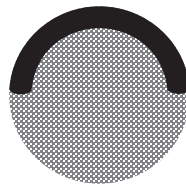

COMPETITORS SELECTIVE INDUCTION HARDENING

Typically, other companies harden only the area that will experience wear. The pin must be oriented properly during assembly to receive the benefit of the induction-hardened surface, and the stop and start area of this induction-hardened zone can promote cracking, ultimately leading to chain failure.

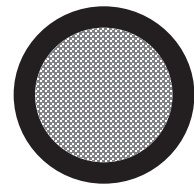

CIRCUMFERENTIAL INDUCTION HARDENING

The load-bearing surface of the thru-hardened pin is induction hardened to 55/60 Rc to the appropriate depth typically 10% of the body diameter is 360°. The IH areas extend into the press fit areas of the pin to maintain the integrity of the pin and guard against failure due to pin shear. This also puts the IH stop and start areas under compression, eliminating potential cracking.

WELDED STEEL MILL CHAINS



Welded steel mill chains are designed for rugged, abrasive and demanding environments. The design allows for operating conditions that are less than desirable. Their rugged welded construction permits high speeds, minimal lubrication and easy modification for application specific attachments.

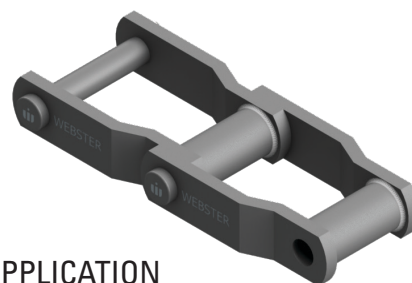

MATERIAL

Sidebars and barrels are medium carbon steel. Pins are medium carbon alloy steel and are thru hardened for maximum chain life. Pins can be induction hardened for even more wear resistance. The WH chains also have thru hardened sidebars and barrels for greater strength and wear resistance. All parts can be furnished with additional heat treatment on request or as the operating environment requires.

ASSEMBLY

Welded steel mill chains are riveted construction with cottered connecting pins. Cottered construction is available on request.

INTERCHANGEABILITY

Welded steel mill chains are interchangeable with other standard makes of corresponding sizes and numbers.

APPLICATION

Welded steel mill chains are used in wood yards, paper mills, OSB plants, grain systems and ethanol processing. They provide long life with very low maintenance.

OPERATION

Maximum chain speed depends upon size of sprockets. For Conveyor Service see Table 2, Section A.

Chain No.	Chain Style	Average Pitch Inches	Approx. Links in 10 Feet	Average Weight Per Ft. Lbs.	Average Ultimate Strength in Lbs.	Rated Working Load in Lbs. ☆	General Dimensions		
							Length of Bearing	℄ To Cotter End	℄ To Head or Rivet End
							X	K	J
WR78	O	2.609	46	4.0	20,000	3,000	2	1 ¹⁹ / ₃₂	1 ⁷ / ₁₆
WH78	O	2.609	46	4.0	30,000	3,500	2	1 ¹⁹ / ₃₂	1 ⁷ / ₁₆
WHC78	S	2.609	46	4.0	30,000	3,500	2	1 ¹⁹ / ₃₂	1 ⁷ / ₁₆
WH78HD	O	2.636	46	6.5	42,700	3,940	2	1 ²³ / ₃₂	1 ¹⁹ / ₃₂
WR78-4	O	4.000	30	4.0	25,900	3,000	2	1 ¹⁹ / ₃₂	1 ⁷ / ₁₆
WH78-4	O	4.000	30	4.0	36,000	3,500	2	1 ¹⁹ / ₃₂	1 ⁷ / ₁₆
WR82	O	3.075	39	4.8	25,000	3,800	2 ¹ / ₄	1 ²³ / ₃₂	1 ¹⁹ / ₃₂
WH82	O	3.075	39	4.8	36,000	4,400	2 ¹ / ₄	1 ²³ / ₃₂	1 ¹⁹ / ₃₂
WHC82	S	3.075	39	4.8	36,000	4,400	2 ¹ / ₄	1 ²³ / ₃₂	1 ¹⁹ / ₃₂
WH82HD	O	3.075	39	7.8	68,000	4,900	2 ¹ / ₄	1 ¹ / ₈	1 ³ / ₄
WH82XHD	O	3.075	39	9.2	62,000	5,900	2 ¹ / ₄	2 ¹ / ₃₂	1 ²⁵ / ₃₂
WR124	O	4.000	30	8.3	47,000	6,200	2 ³ / ₄	2 ³ / ₃₂	2 ¹ / ₃₂
WH124	O	4.000	30	8.3	69,000	7,200	2 ³ / ₄	2 ³ / ₃₂	2 ¹ / ₃₂
WHX124	O	4.000	30	8.3	69,000	7,200	2 ³ / ₄	2 ³ / ₃₂	2 ¹ / ₃₂
WHC124	S	4.000	30	8.3	69,000	7,200	2 ³ / ₄	2 ³ / ₃₂	2 ¹ / ₃₂
WH124HDSPC	O	4.063	30	14.7	100,000	10,500	3	2 ¹ / ₃₂	2 ³ / ₈
WH124XHD	O	4.063	30	17.4	129,000	11,375	3 ¹ / ₄	2 ¹³ / ₁₆	2 ⁵ / ₈
WH144	O	4.000	30	10.5	69,000	9,600	2 ³ / ₄	2 ³ / ₃₂	2 ³ / ₃₂
WR111+	O	4.760	26	9.5	52,000	7,500	3 ³ / ₈	2 ¹⁹ / ₃₂	2 ¹¹ / ₃₂
WH111+	O	4.760	26	9.5	77,000	8,850	3 ³ / ₈	2 ¹⁹ / ₃₂	2 ¹¹ / ₃₂
WHC111+	S	4.760	26	9.5	77,000	8,850	3 ³ / ₈	2 ¹⁹ / ₃₂	2 ¹¹ / ₃₂
WH111+HD	O	4.760	26	13.2	77,000	9,500	3 ⁵ / ₈	2 ²⁵ / ₃₂	2 ¹⁹ / ₃₂

NOTE: Supplied in 10' strands but available up to 40' upon request at no additional cost.

☆ Subject to Service Factor see Table 9 and Speed Factor Table 10, Section A, in Webster #400 Master Catalog.



WELDED STEEL MILL CHAINS

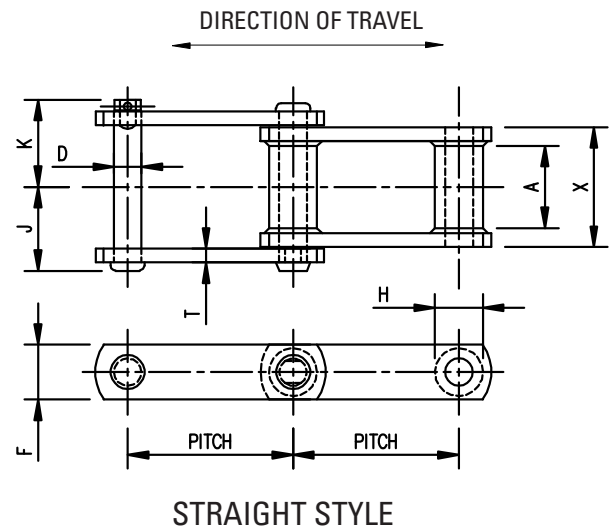
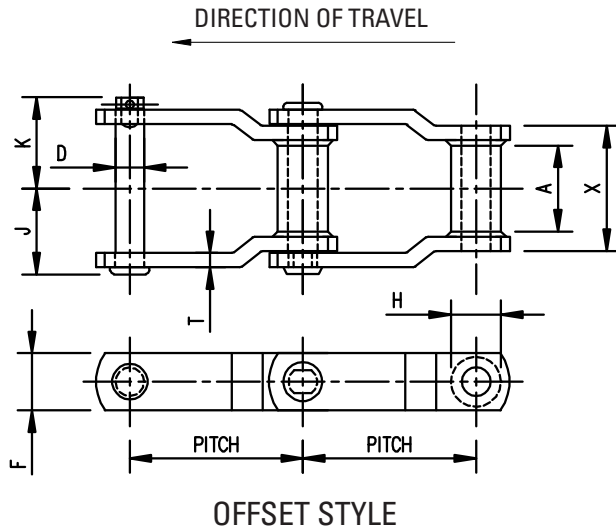

Abbreviations of Material and Treatment
 M.C. Medium Carbon
 M.C.H.T. Medium Carbon, Heat Treated
 ALY.H.T. Alloy Steel, Heat Treated
 ALY.I.H. Alloy Steel, Induction Hardened

Chain No.	Pins		Sidebars			Barrels		Max. Spkt. Width A	Common Attachment Numbers
	Dia. D	Material	Thk. T	Height F	Material	Outside Dia. H	Material		
WR78	1/2	ALY.H.T.	1/4	1 1/8	M.C.	7/8	M.C.	1 1/8	A12, A22, F2, F4, G19, H1, H2, K1, K2, RF2, ROOFTOP, RR, SIDE LIFT CHAIR
WH78	1/2	ALY.H.T.	1/4	1 1/8	M.C.H.T.	7/8	M.C.H.T.	1 1/8	
WHC78	1/2	ALY.H.T.	1/4	1 1/8	M.C.H.T.	7/8	M.C.H.T.	1 1/8	
WH78HD	9/16	ALY.H.T.	3/8	1 1/4	M.C.H.T.	1	M.C.H.T.	7/8	K2
WR78-4	1/2	ALY.H.T.	1/4	1 1/4	M.C.	7/8	M.C.	1 1/8	
WH78-4	1/2	ALY.H.T.	1/4	1 1/4	M.C.H.T.	7/8	M.C.H.T.	1 1/8	
WR82	9/16	ALY.H.T.	1/4	1 1/4	M.C.	1 1/16	M.C.	1 1/4	A22, A42, AD474, F4, H1, H2, K1, K2, RR, SIDE LIFT CHAIR
WH82	9/16	ALY.H.T.	1/4	1 1/4	M.C.H.T.	1 1/16	M.C.H.T.	1 1/4	
WHC82	9/16	ALY.H.T.	1/4	1 1/4	M.C.H.T.	1 1/16	M.C.H.T.	1 1/4	
WH82HD	5/8	ALY.H.T.	3/8	1 1/2	M.C.H.T.	1 1/16	M.C.H.T.	1	K1, K2, SIDE LIFT CHAIR
WH82XHD	3/4	ALY.H.T.	3/8	1 1/2	M.C.H.T.	1 1/4	M.C.H.T.	1	K2, SIDE LIFT CHAIR
WR124	3/4	ALY.H.T.	3/8	1 1/2	M.C.	1 1/4	M.C.	1 1/2	A22OSB, A27, C CRADLE, F4, K1, K2, RF2, RR, S1, SIDE LIFT CHAIR
WH124	3/4	ALY.H.T.	3/8	1 1/2	M.C.H.T.	1 1/4	M.C.H.T.	1 1/2	
WHX124	3/4	ALY.I.H.	3/8	1 1/2	M.C.H.T.	1 1/4	M.C.H.T.	1 1/2	
WHC124	3/4	ALY.H.T.	3/8	1 1/2	M.C.H.T.	1 1/4	M.C.H.T.	1 1/2	
WH124HDSPC	1	ALY.H.T.	1/2	2	M.C.H.T.	1 3/4	M.C.H.T.	1 1/2	A22OSB, A & C CRADLE, K2, RF2, SIDE LIFT CHAIR
WH124XHD	1	ALY.H.T.	5/8	2	M.C.H.T.	1 3/4	M.C.H.T.	1 1/2	A22OSB, C CRADLE, SIDE LIFT CHAIR
WH144	1	ALY.H.T.	3/8	1 3/4	M.C.H.T.	1 5/8	M.C.H.T.	1 1/2	A22OSB
WR111+	3/4	ALY.H.T.	3/8	1 3/4	M.C.	1 1/4	M.C.	2	A & C CRADLE, K1, K2
WH111+	3/4	ALY.H.T.	3/8	1 3/4	M.C.H.T.	1 1/4	M.C.H.T.	2	A & C CRADLE, K1, K2
WHC111+	3/4	ALY.H.T.	3/8	1 3/4	M.C.H.T.	1 1/4	M.C.H.T.	2	
WH111+HD	3/4	ALY.H.T.	1/2	2	M.C.H.T.	1 7/16	M.C.H.T.	2	

WELDED STEEL MILL CHAINS

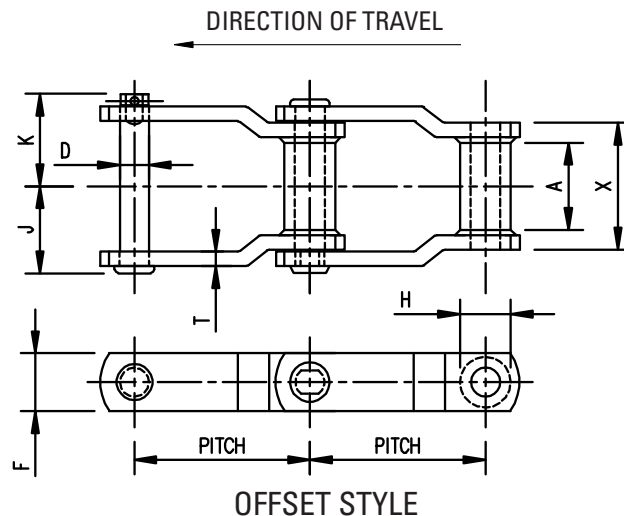

Chain No.	Chain Style	Average Pitch Inches	Approx. Links in 10 Feet	Average Weight Per Ft. Lbs.	Average Ultimate Strength in Lbs.	Rated Working Load in Lbs. ☆	General Dimensions		
							Length of Bearing	℄ To Cotter End	℄ To Head or Rivet End
							X	K	J
WR110	O	6.000	20	7.2	47,000	6,750	3	2 ¹¹ / ₃₂	2 ⁹ / ₃₂
WH110	O	6.000	20	7.2	69,000	7,875	3	2 ¹¹ / ₃₂	2 ⁹ / ₃₂
WR106	O	6.000	20	7.0	47,000	6,200	2 ⁹ / ₃₂	2 ⁹ / ₃₂	2 ¹ / ₃₂
WH106	O	6.000	20	7.0	69,000	7,200	2 ⁹ / ₃₂	2 ⁹ / ₃₂	2 ¹ / ₃₂
WHX106	O	6.000	20	7.0	69,000	7,200	2 ⁹ / ₃₂	2 ⁹ / ₃₂	2 ¹ / ₃₂
WHC106	S	6.000	20	7.0	69,000	7,200	2 ⁹ / ₃₂	2 ⁹ / ₃₂	2 ¹ / ₃₂
WH106HD	O	6.000	20	9.0	92,500	7,875	3	2 ¹ / ₂	2 ⁵ / ₁₆
WH106XHD	O	6.050	20	11.8	115,000	10,500	3	2 ¹⁷ / ₃₂	2 ³ / ₈
WH166	O	6.000	20	8.5	69,000	9,600	2 ⁹ / ₃₂	2 ⁹ / ₃₂	2 ⁹ / ₃₂
WR132	O	6.050	20	14.2	78,000	13,000	4 ⁹ / ₃₂	3 ³ / ₃₂	3 ¹ / ₁₆
WH132	O	6.050	20	14.2	115,000	15,300	4 ⁹ / ₃₂	3 ³ / ₃₂	3 ¹ / ₁₆
WHX132	O	6.050	20	14.2	115,000	15,300	4 ⁹ / ₃₂	3 ³ / ₃₂	3 ¹ / ₁₆
WHC132	S	6.050	20	14.2	115,000	15,300	4 ⁹ / ₃₂	3 ³ / ₃₂	3 ¹ / ₁₆
WH132HD	O	6.050	20	16.4	152,000	16,200	4 ⁵ / ₈	3 ¹ / ₂	3 ⁵ / ₁₆
WH132XHD	O	6.050	20	18.6	182,000	17,000	4 ⁷ / ₈	3 ³ / ₄	3 ¹ / ₂
WR150	O	6.050	20	16.8	78,000	13,000	4 ⁹ / ₃₂	3 ³ / ₃₂	3 ¹ / ₁₆
WH150	O	6.050	20	16.8	116,000	15,300	4 ⁹ / ₃₂	3 ³ / ₃₂	3 ¹ / ₁₆
WHX150	O	6.050	20	16.8	116,000	15,300	4 ⁹ / ₃₂	3 ³ / ₃₂	3 ¹ / ₁₆
WH150HD	O	6.050	20	19.3	168,000	16,200	4 ⁵ / ₈	3 ¹ / ₂	3 ⁵ / ₁₆
WH157	O	6.050	20	20.6	161,000	18,200	4 ⁵ / ₈	3 ⁹ / ₁₆	3 ³ / ₈
WHX157	O	6.050	20	20.6	161,000	18,200	4 ⁵ / ₈	3 ⁹ / ₁₆	3 ³ / ₈
WHC157	S	6.050	20	20.6	161,000	18,200	4 ⁵ / ₈	3 ⁹ / ₁₆	3 ³ / ₈
WHX157XHD	O	6.050	20	23.7	200,000	33,000	4 ⁵ / ₈	3 ⁹ / ₁₆	3 ⁵ / ₁₆
WHX155	O	6.050	20	19.0	145,000	17,750	4 ¹ / ₂	3 ¹ / ₂	3 ³ / ₈
WHX200	O	6.050	20	22.0	190,000	20,225	4 ⁵ / ₈	3 ⁹ / ₁₆	3 ⁵ / ₁₆
WHX159	O	6.125	20	26.5	230,000	20,250	4 ⁵ / ₈	3 ⁹ / ₁₆	3 ⁵ / ₁₆
WHX2012A	O	12.000	10	15.6	200,000	33,000	4 ⁵ / ₈	3 ⁹ / ₁₆	3 ⁵ / ₁₆
WHX3012	O	12.000	10	18.2	200,000	33,000	4 ⁵ / ₈	3 ⁹ / ₁₆	3 ⁵ / ₁₆

NOTE: Supplied in 10' strands but available up to 40' upon request at no additional cost.

☆ Subject to Service Factor see Table 9 and Speed Factor Table 10, Section A, in Webster #400 Master Catalog.



WELDED STEEL MILL CHAINS

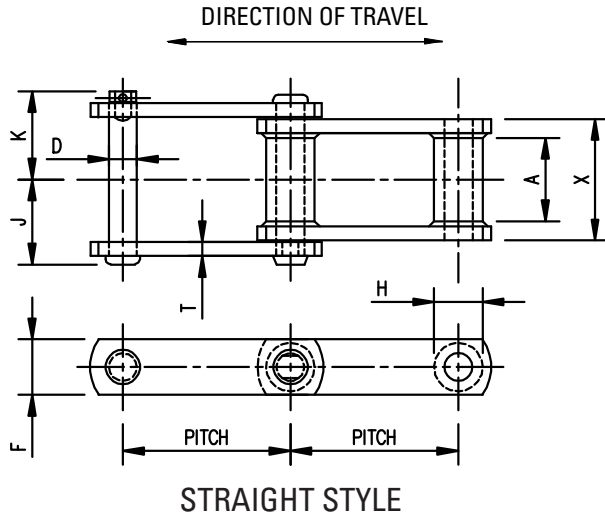

Abbreviations of Material and Treatment
M.C. Medium Carbon
M.C.H.T. Medium Carbon, Heat Treated
ALY.H.T. Alloy Steel, Heat Treated
ALY.I.H. Alloy Steel, Induction Hardened

Chain No.	Pins		Sidebars			Barrels		Max. Spkt. Width A	Common Attachment Numbers
	Dia.	Material	Thk.	Height	Material	Outside Dia.	Material		
	D		T	F		H			
WR110	3/4	ALY.H.T.	3/8	1 1/2	M.C.	1 1/4	M.C.	1 3/4	K2
WH110	3/4	ALY.H.T.	3/8	1 1/2	M.C.H.T.	1 1/4	M.C.H.T.	1 3/4	K2
WR106	3/4	ALY.H.T.	3/8	1 1/2	M.C.	1 1/4	M.C.	1 1/2	A220SB, C CRADLE, K2
WH106	3/4	ALY.H.T.	3/8	1 1/2	M.C.H.T.	1 1/4	M.C.H.T.	1 1/2	A220SB, C CRADLE, K2
WHX106	3/4	ALY.I.H.	3/8	1 1/2	M.C.H.T.	1 1/4	M.C.H.T.	1 1/2	A220SB, C CRADLE, K2
WHC106	3/4	ALY.H.T.	3/8	1 1/2	M.C.H.T.	1 1/4	M.C.H.T.	1 1/2	
WH106HD	3/4	ALY.H.T.	1/2	1 1/2	M.C.H.T.	1 1/4	M.C.H.T.	1 1/2	A220SB
WH106XHD	1	ALY.H.T.	1/2	2	M.C.H.T.	1 3/4	M.C.H.T.	1 1/2	A220SB, C CRADLE
WH166	1	ALY.H.T.	3/8	1 3/4	M.C.H.T.	1 5/8	M.C.H.T.	1 1/2	A220SB
WR132	1	ALY.H.T.	1/2	2	M.C.	1 3/4	M.C.	2 3/4	A22, A220SB, A42, A B & C CRADLE, K2, M1, PC47, PETER FLIGHTS, RF3, S1, SIDE LIFT CHAIR
WH132	1	ALY.H.T.	1/2	2	M.C.H.T.	1 3/4	M.C.H.T.	2 3/4	
WHX132	1	ALY.I.H.	1/2	2	M.C.H.T.	1 3/4	M.C.H.T.	2 3/4	
WHC132	1	ALY.H.T.	1/2	2	M.C.H.T.	1 3/4	M.C.H.T.	2 3/4	
WH132HD	1	ALY.H.T.	5/8	2	M.C.H.T.	1 3/4	M.C.H.T.	2 3/4	A220SB, A42, A & C CRADLE, K2, M1, PETER FLIGHTS, S1
WH132XHD	1	ALY.H.T.	3/4	2	M.C.H.T.	1 3/4	M.C.H.T.	2 3/4	C CRADLE
WR150	1	ALY.H.T.	1/2	2 1/2	M.C.	1 3/4	M.C.	2 3/4	C CRADLE, K2, M1, RF3, RF12, RF18, S1
WH150	1	ALY.H.T.	1/2	2 1/2	M.C.H.T.	1 3/4	M.C.H.T.	2 3/4	
WHX150	1	ALY.I.H.	1/2	2 1/2	M.C.H.T.	1 3/4	M.C.H.T.	2 3/4	
WH150HD	1	ALY.H.T.	5/8	2 1/2	M.C.H.T.	1 3/4	M.C.H.T.	2 3/4	A CRADLE
WH157	1 1/8	ALY.H.T.	5/8	2 1/2	M.C.H.T.	1 3/4	M.C.H.T.	2 3/4	A42, A & C CRADLE, K2, M1, PETER FLIGHTS, RF12, RF18, S1
WHX157	1 1/8	ALY.I.H.	5/8	2 1/2	M.C.H.T.	1 3/4	M.C.H.T.	2 3/4	
WHC157	1 1/8	ALY.H.T.	5/8	2 1/2	M.C.H.T.	1 3/4	M.C.H.T.	2 3/4	
WHX157XHD	1 1/4	ALY.I.H.	5/8	3	M.C.H.T.	1 3/4	M.C.H.T.	2 3/4	
WHX155	1 1/8	ALY.I.H.	9/16	2 1/2	M.C.H.T.	1 3/4	M.C.H.T.	2 3/4	C CRADLE, M1
WHX200	1 1/4	ALY.I.H.	5/8	2 1/2	M.C.H.T.	1 3/4	M.C.H.T.	2 3/4	
WHX159	1 1/4	ALY.I.H.	5/8	3	M.C.H.T.	2	M.C.H.T.	2 3/4	
WHX2012A	1 1/4	ALY.I.H.	5/8	2 1/2	M.C.H.T.	1 3/4	M.C.H.T.	2 3/4	
WHX3012	1 1/4	ALY.I.H.	5/8	3	M.C.H.T.	1 3/4	M.C.H.T.	2 3/4	

COMMON MILL CHAIN ATTACHMENTS



A12

Chain No.	A	B	C	E	F	H	T	Weight Per Foot-Lbs.	Bolt Size
								Δ	
WR78	2	1 $\frac{1}{4}$	2 $\frac{3}{4}$	1	3 $\frac{3}{16}$	$\frac{5}{16}$	$\frac{1}{4}$	4.6	$\frac{1}{4}$
WH78	2	1 $\frac{1}{4}$	2 $\frac{3}{4}$	1	3 $\frac{3}{16}$	$\frac{5}{16}$	$\frac{1}{4}$	4.6	$\frac{1}{4}$

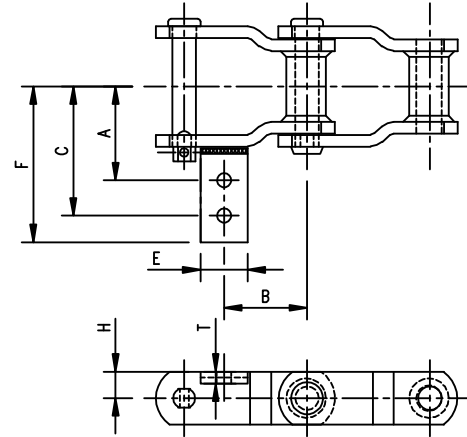

A12

A22

Chain No.	A	B	E	F	T	Weight Per Foot-Lbs.	Bolt Size
						Δ	
WR78	1 $\frac{7}{8}$	1 $\frac{5}{8}$	1	2 $\frac{1}{2}$	$\frac{3}{8}$	4.6	$\frac{3}{8}$
WH78	1 $\frac{7}{8}$	1 $\frac{5}{8}$	1	2 $\frac{1}{2}$	$\frac{3}{8}$	4.6	$\frac{3}{8}$
WR82	2 $\frac{1}{8}$	1 $\frac{7}{8}$	1 $\frac{1}{4}$	2 $\frac{11}{16}$	$\frac{1}{4}$	5.2	$\frac{3}{8}$
WH82	2 $\frac{1}{8}$	1 $\frac{7}{8}$	1 $\frac{1}{4}$	2 $\frac{11}{16}$	$\frac{1}{4}$	5.2	$\frac{3}{8}$
WR132	4	3 $\frac{3}{4}$	1 $\frac{1}{2}$	4 $\frac{3}{4}$	$\frac{1}{2}$	15.0	$\frac{1}{2}$
WH132	4	3 $\frac{3}{4}$	1 $\frac{1}{2}$	4 $\frac{3}{4}$	$\frac{1}{2}$	15.0	$\frac{1}{2}$
WHX132	4	3 $\frac{3}{4}$	1 $\frac{1}{2}$	4 $\frac{3}{4}$	$\frac{1}{2}$	15.0	$\frac{1}{2}$

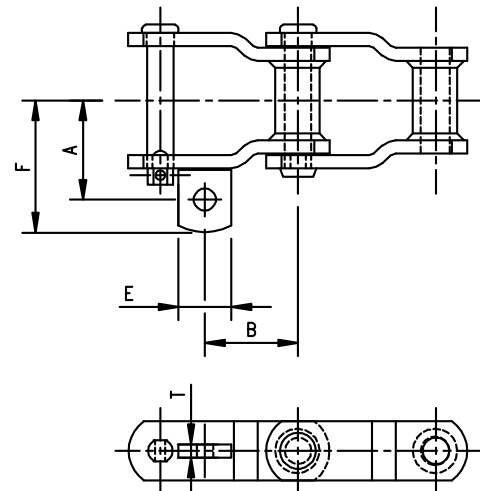

A22, A27 AND A42

A27

WR124	3	2	1 $\frac{1}{2}$	3 $\frac{3}{4}$	$\frac{1}{2}$	9.2	$\frac{1}{2}$
WH124	3	2	1 $\frac{1}{2}$	3 $\frac{3}{4}$	$\frac{1}{2}$	9.2	$\frac{1}{2}$
WHX124	3	2	1 $\frac{1}{2}$	3 $\frac{3}{4}$	$\frac{1}{2}$	9.2	$\frac{1}{2}$

A42

WR82	3 $\frac{5}{8}$	1 $\frac{7}{8}$	1 $\frac{1}{2}$	3 $\frac{1}{4}$	$\frac{1}{2}$	6.2	$\frac{5}{8}$
WH82	3 $\frac{5}{8}$	1 $\frac{7}{8}$	1 $\frac{1}{2}$	3 $\frac{1}{4}$	$\frac{1}{2}$	6.2	$\frac{5}{8}$
WR132	4 $\frac{1}{2}$	3 $\frac{1}{2}$	2 $\frac{1}{2}$	5 $\frac{3}{4}$	$\frac{3}{4}$	16.8	$\frac{7}{8}$
WH132	4 $\frac{1}{2}$	3 $\frac{1}{2}$	2 $\frac{1}{2}$	5 $\frac{3}{4}$	$\frac{3}{4}$	16.8	$\frac{7}{8}$
WHX132	4 $\frac{1}{2}$	3 $\frac{1}{2}$	2 $\frac{1}{2}$	5 $\frac{3}{4}$	$\frac{3}{4}$	16.8	$\frac{7}{8}$
WH132HD	4 $\frac{5}{8}$	3 $\frac{3}{4}$	2	5 $\frac{7}{8}$	$\frac{3}{4}$	18.7	$\frac{3}{4}$
WH157	5 $\frac{1}{4}$	3	2 $\frac{1}{4}$	6 $\frac{3}{8}$	$\frac{3}{4}$	23.9	1
WHX157	5 $\frac{1}{4}$	3	2 $\frac{1}{4}$	6 $\frac{3}{8}$	$\frac{3}{4}$	23.9	1



COMMON MILL CHAIN ATTACHMENTS

A220SB

Chain No.	A	B	C	D	E	F	T	Weight Per Foot-Lbs.	Bolt Size
								Δ	
WR124	4	2 $\frac{1}{4}$	1 $\frac{3}{16}$	1 $\frac{1}{2}$	2	5 $\frac{15}{16}$	1 $\frac{1}{2}$	11.9	3 $\frac{3}{4}$
WH124	4	2 $\frac{1}{4}$	1 $\frac{3}{16}$	1 $\frac{1}{2}$	2	5 $\frac{15}{16}$	1 $\frac{1}{2}$	11.9	3 $\frac{3}{4}$
WHX124	4	2 $\frac{1}{4}$	1 $\frac{3}{16}$	1 $\frac{1}{2}$	2	5 $\frac{15}{16}$	1 $\frac{1}{2}$	11.9	3 $\frac{3}{4}$
WH124HDSPC	4	2 $\frac{1}{32}$	1 $\frac{3}{16}$	1 $\frac{1}{2}$	2 $\frac{1}{2}$	5 $\frac{15}{16}$	1 $\frac{1}{2}$	18.8	3 $\frac{3}{4}$
WH124XHD	4 $\frac{1}{2}$	2 $\frac{5}{16}$	1 $\frac{3}{16}$	1 $\frac{1}{2}$	2	6	5 $\frac{5}{8}$	21.5	3 $\frac{3}{4}$
WR106	4	3 $\frac{1}{2}$	1 $\frac{3}{16}$	1 $\frac{1}{2}$	3	6	1 $\frac{1}{2}$	10.4	3 $\frac{3}{4}$
WH106	4	3 $\frac{1}{2}$	1 $\frac{3}{16}$	1 $\frac{1}{2}$	3	6	1 $\frac{1}{2}$	10.4	3 $\frac{3}{4}$
WHX106	4	3 $\frac{1}{2}$	1 $\frac{3}{16}$	1 $\frac{1}{2}$	3	6	1 $\frac{1}{2}$	10.4	3 $\frac{3}{4}$
WH106HD	4	3	1 $\frac{3}{16}$	1 $\frac{1}{2}$	3	5 $\frac{15}{16}$	5 $\frac{5}{8}$	12.0	3 $\frac{3}{4}$
WH106XHD	4	3 $\frac{1}{4}$	1 $\frac{3}{16}$	1 $\frac{1}{2}$	3	6	1 $\frac{1}{2}$	14.9	3 $\frac{3}{4}$
WR132	4 $\frac{1}{2}$	3 $\frac{1}{8}$	1 $\frac{3}{16}$	1 $\frac{1}{2}$	2	6 $\frac{1}{4}$	1 $\frac{1}{2}$	16.3	3 $\frac{3}{4}$
WH132	4 $\frac{1}{2}$	3 $\frac{1}{8}$	1 $\frac{3}{16}$	1 $\frac{1}{2}$	2	6 $\frac{1}{4}$	1 $\frac{1}{2}$	16.3	3 $\frac{3}{4}$
WHX132	4 $\frac{1}{2}$	3 $\frac{1}{8}$	1 $\frac{3}{16}$	1 $\frac{1}{2}$	2	6 $\frac{1}{4}$	1 $\frac{1}{2}$	16.3	3 $\frac{3}{4}$
WH132HD	5 $\frac{1}{2}$	3 $\frac{1}{8}$	1 $\frac{3}{16}$	1 $\frac{1}{2}$	2	6 $\frac{3}{4}$	1	19.2	3 $\frac{3}{4}$
WH144	4	2	1 $\frac{3}{16}$	1 $\frac{1}{2}$	2	5 $\frac{15}{16}$	1 $\frac{1}{2}$	13.8	3 $\frac{3}{4}$
WH166	4	3 $\frac{1}{2}$	1 $\frac{3}{16}$	1 $\frac{1}{2}$	2 $\frac{1}{2}$	6	1 $\frac{1}{2}$	11.3	3 $\frac{3}{4}$

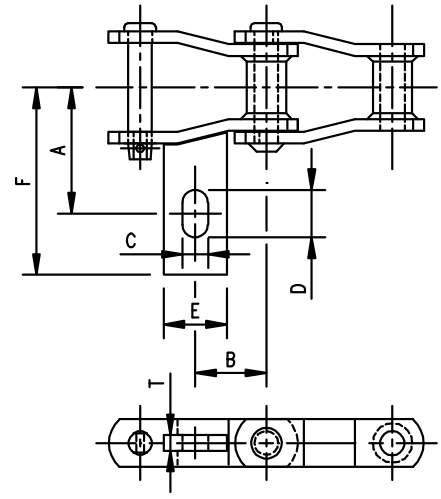

A220SB

AD474

Chain No.	A	B	C	E	F	T	Weight Per Foot-Lbs.	Bolt Size
							Δ	
WR82	3 $\frac{3}{8}$	1 $\frac{13}{16}$	5 $\frac{7}{8}$	1 $\frac{1}{2}$	6 $\frac{7}{8}$	1 $\frac{1}{2}$	9.2	1 $\frac{1}{2}$
WH82	3 $\frac{3}{8}$	1 $\frac{13}{16}$	5 $\frac{7}{8}$	1 $\frac{1}{2}$	6 $\frac{7}{8}$	1 $\frac{1}{2}$	9.2	1 $\frac{1}{2}$

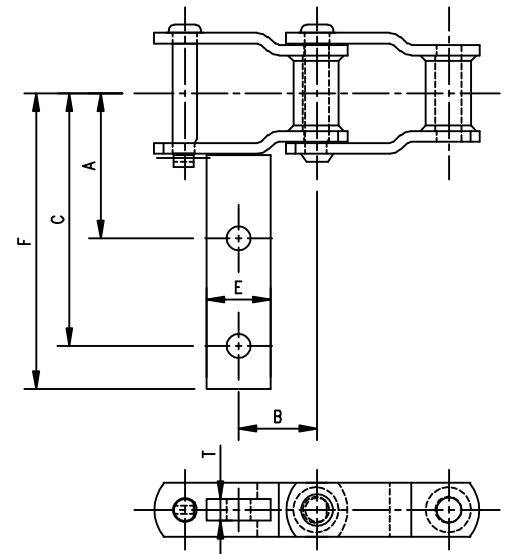

AD474

COMMON MILL CHAIN ATTACHMENTS

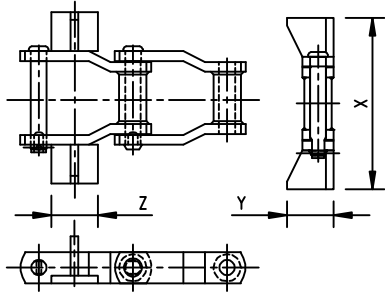

STYLE A

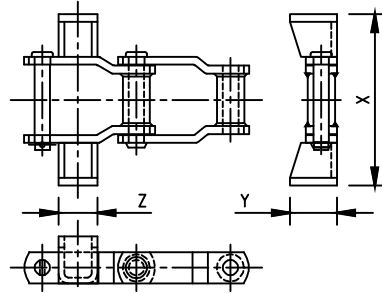

STYLE B

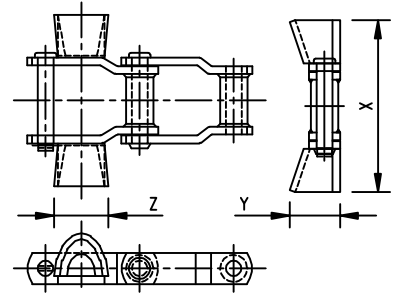

STYLE C

CRADLES

Chain No.	Style A Dimensions				Style B Dimensions				Style C Dimensions			
	X	Y	Z	Weight Per Pair-Lbs.	X	Y	Z	Weight Per Pair-Lbs.	X	Y	Z	Weight Per Pair-Lbs.
WR106	—	—	—	—	—	—	—	—	8	2½	3	4.0
WH106	—	—	—	—	—	—	—	—	8	2½	3	4.0
WHX106	—	—	—	—	—	—	—	—	8	2½	3	4.0
WR111+	—	—	—	—	—	—	—	—	8	2⅝	2½	4.0
WH111+	—	—	—	—	—	—	—	—	8	2⅝	2½	4.0
WR124	—	—	—	—	—	—	—	—	8	2½	2½	4.0
WH124	—	—	—	—	—	—	—	—	8	2½	2½	4.0
WHX124	—	—	—	—	—	—	—	—	8	2½	2½	4.0
WH124HDSPC	8	2⅝	2¼	2.5	—	—	—	—	8	3	2½	5.0
WR124	—	—	—	—	—	—	—	—	9	2½	2½	4.5
WH124	—	—	—	—	—	—	—	—	9	2½	2½	4.5
WHX124	—	—	—	—	—	—	—	—	9	2½	2½	4.5
WH124HDSPC	10	3	2	5.0	—	—	—	—	—	—	—	—
WR111+	10¼	3	1¾	6.0	—	—	—	—	—	—	—	—
WH111+	10¼	3	1¾	6.0	—	—	—	—	—	—	—	—
WR111+	—	—	—	—	—	—	—	—	11	2⅞	2⅝	6.5
WH111+	—	—	—	—	—	—	—	—	11	2⅞	2⅝	6.5
WR111+	11½	2½	2½	5.0	—	—	—	—	—	—	—	—
WH111+	11½	2½	2½	5.0	—	—	—	—	—	—	—	—
WR124	—	—	—	—	—	—	—	—	11	2½	2½	6.0
WH124	—	—	—	—	—	—	—	—	11	2½	2½	6.0
WHX124	—	—	—	—	—	—	—	—	11	2½	2½	6.0
WH124XHD	—	—	—	—	—	—	—	—	11	¾	2½	7.0
WR132	11	3	3	6.0	11	3	2½	6.0	11	¾	3½	6.0
WH132	11	3	3	6.0	11	3	2½	6.0	11	¾	3½	6.0
WHX132	11	3	3	6.0	11	3	2½	6.0	11	¾	3½	6.0
WH132HD	11	3	3	6.0	—	—	—	—	11	¾	3½	8.0
WH132XHD	—	—	—	—	—	—	—	—	11	¾	3½	8.0
WR150	—	—	—	—	—	—	—	—	11	¾	3½	8.0
WH150	—	—	—	—	—	—	—	—	11	¾	3½	8.0
WHX150	—	—	—	—	—	—	—	—	11	¾	3½	8.0
WH150HD	11	3½	2½	6.0	—	—	—	—	—	—	—	—



COMMON MILL CHAIN ATTACHMENTS

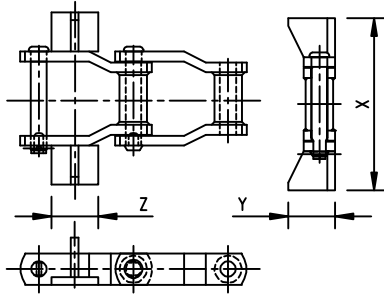

STYLE A

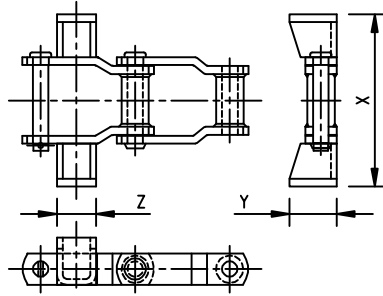

STYLE B

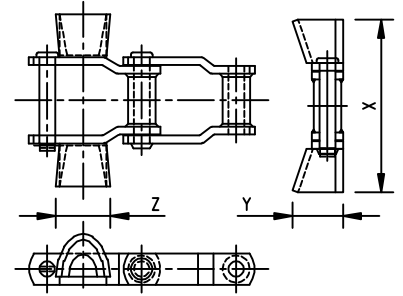

STYLE C

CRADLES

Chain No.	Style A Dimensions				Style B Dimensions				Style C Dimensions			
	X	Y	Z	Weight Per Pair-Lbs.	X	Y	Z	Weight Per Pair-Lbs.	X	Y	Z	Weight Per Pair-Lbs.
WHX155	—	—	—	—	—	—	—	—	11	3½	3½	8.0
WH157	11	3½	2½	10.0	—	—	—	—	11	3½	3½	8.0
WHX157	11	3½	2½	10.0	—	—	—	—	11	3½	3½	8.0
WH106XHD	—	—	—	—	—	—	—	—	12	3½	3½	12.0
WH157	—	—	—	—	—	—	—	—	12	3½	3½	9.0
WHX157	—	—	—	—	—	—	—	—	12	3½	3½	9.0
WR111+	—	—	—	—	—	—	—	—	13	3	2¾	10.0
WH111+	—	—	—	—	—	—	—	—	13	3	2¾	10.0
WR132	—	—	—	—	13	3	2½	7.5	13	3½	3¾	9.0
WH132	—	—	—	—	13	3	2½	7.5	13	3½	3¾	9.0
WHX132	—	—	—	—	13	3	2½	7.5	13	3½	3¾	9.0
WH132HD	—	—	—	—	—	—	—	—	13	3½	3½	9.0
WH132XHD	—	—	—	—	—	—	—	—	13	3½	3½	11.0
WR150	—	—	—	—	—	—	—	—	13	3½	3¾	9.0
WH150	—	—	—	—	—	—	—	—	13	3½	3¾	9.0
WHX150	—	—	—	—	—	—	—	—	13	3½	3¾	9.0
WH157	—	—	—	—	—	—	—	—	13	4	3½	12.0
WHX157	—	—	—	—	—	—	—	—	13	4	3½	12.0
WR111+	—	—	—	—	—	—	—	—	14	3½	2¾	11.0
WH111+	—	—	—	—	—	—	—	—	14	3½	2¾	11.0
WH124HDSPC	15½	3½	2	14.5	—	—	—	—	—	—	—	—
WR132	—	—	—	—	—	—	—	—	15	3¾	3¾	10.0
WH132	—	—	—	—	—	—	—	—	15	3¾	3¾	10.0
WHX132	—	—	—	—	—	—	—	—	15	3¾	3¾	10.0
WH132HD	—	—	—	—	—	—	—	—	15	3¾	3½	10.0
WHX155	—	—	—	—	—	—	—	—	16	4	4	10.0
WHX155	—	—	—	—	—	—	—	—	17	4	4	22.0
WH157	—	—	—	—	—	—	—	—	17	4¼	4	20.0
WHX157	—	—	—	—	—	—	—	—	17	4¼	4	20.0
WR132	—	—	—	—	—	—	—	—	18	3½	3¾	15.0
WH132	—	—	—	—	—	—	—	—	18	3½	3¾	15.0
WHX132	—	—	—	—	—	—	—	—	18	3½	3¾	15.0
WHX155	—	—	—	—	—	—	—	—	19	4½	4	21.0

COMMON MILL CHAIN ATTACHMENTS



F2

Chain No.	A	B	E	F	G	H	J	T	Weight Per Foot-Lbs.	Bolt Size
									Δ	
WR78	—	1/2	—	4 11/16	7/8	2 5/16	3 3/4	1/4	7.6	3/8
WH78	—	1/2	—	4 11/16	7/8	2 5/16	3 3/4	1/4	7.6	3/8

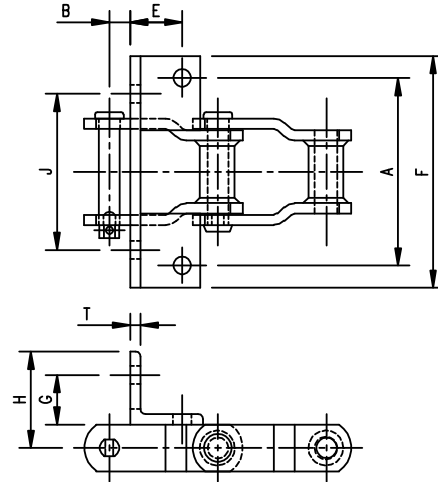

F2 AND F4

F4

Chain No.	A	B	E	F	G	H	J	T	Weight Per Foot-Lbs.	Bolt Size
									Δ	
WR78	4 1/2	1/2	1 1/4	5 9/16	1 3/16	2 5/16	3 3/4	1/4	8.6	3/8
WH78	4 1/2	1/2	1 1/4	5 9/16	1 3/16	2 5/16	3 3/4	1/4	8.6	3/8
WR82	5	13/16	1 1/8	5 15/16	1 3/16	2 3/8	4 1/8	1/4	8.9	3/8
WH82	5	13/16	1 1/8	5 15/16	1 3/16	2 3/8	4 1/8	1/4	8.9	3/8
WR124	5 1/4	7/8	1 7/16	6 3/16	1 5/16	2 3/4	4 3/8	3/8	14.0	3/8
WH124	5 1/4	7/8	1 7/16	6 3/16	1 5/16	2 3/4	4 3/8	3/8	14.0	3/8
WHX124	5 1/4	7/8	1 7/16	6 3/16	1 5/16	2 3/4	4 3/8	3/8	14.0	3/8

G19

Chain No.	A	B	C	F	H	T	Weight Per Foot-Lbs.	Bolt Size
							Δ	
WR78	2 3/16	2	1 5/16	2 13/16	1 15/16	1/4	6.3	3/8
WH78	2 3/16	2	1 5/16	2 13/16	1 15/16	1/4	6.3	3/8

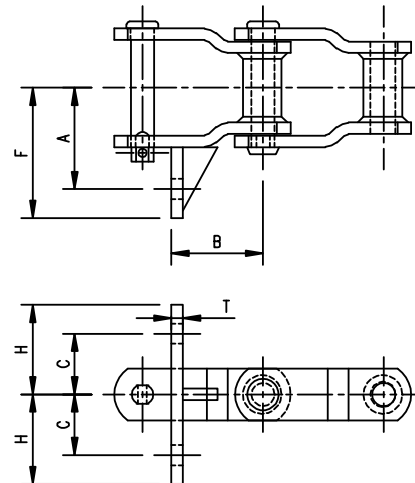

G19

H1

Chain No.	B	H	S	T	Weight Per Foot-Lbs.
					Δ
WR78	1/2	3 5/8	1 1/2	3/16	7.2
WH78	1/2	3 5/8	1 1/2	3/16	7.2
WR82	5/8	3 5/8	1 3/4	3/16	7.9
WH82	5/8	3 5/8	1 3/4	3/16	7.9

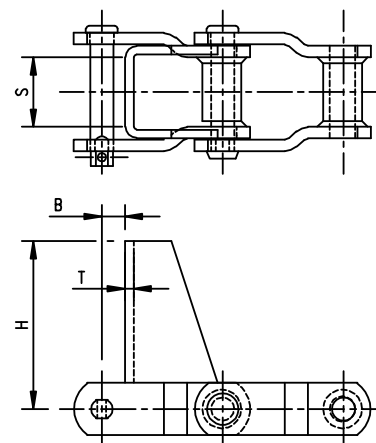

H1



COMMON MILL CHAIN ATTACHMENTS

H2

Chain No.	B	H	S	T	Weight Per Foot-Lbs.
					Δ
WR78	1/2	3/8	1 1/2	3/16	7.4
WH78	1/2	3/8	1 1/2	3/16	7.4
WR82	5/8	3/8	1 3/4	3/16	7.5
WH82	5/8	3/8	1 3/4	3/16	7.5

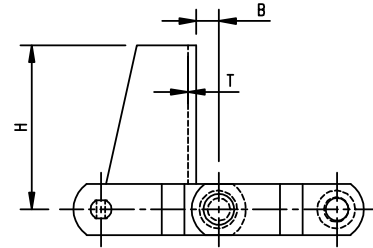
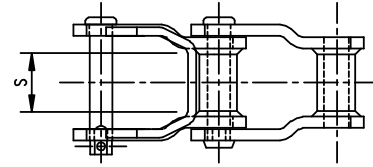

H2

K1

Chain No.	A	B	C	E	F	T	Weight Per Foot-Lbs.	Bolt Size
							Δ	
WR78	2	1 1/4	1 9/16	1 1/4	2 1/2	1/4	5.1	3/8
WH78	2	1 1/4	1 9/16	1 1/4	2 1/2	1/4	5.1	3/8
WR82	2 1/8	1 1/2	7/8	1 1/4	2 3/4	1/4	6.3	3/8
WH82	2 1/8	1 1/2	7/8	1 1/4	2 3/4	1/4	6.3	3/8
WH82HD	2 1/8	1 1/2	1 1/8	1 3/4	2 3/4	3/8	9.9	3/8
WR124	2 5/8	1 9/16	1 1/8	2	3 1/4	3/8	10.6	5/8
WH124	2 5/8	1 9/16	1 1/8	2	3 1/4	3/8	10.6	5/8
WHX124	2 5/8	1 9/16	1 1/8	2	3 1/4	3/8	10.6	5/8
WR111+	3 1/8	2 3/8	1 1/4	2	3 7/8	3/8	11.8	1/2
WH111+	3 1/8	2 3/8	1 1/4	2	3 7/8	3/8	11.8	1/2

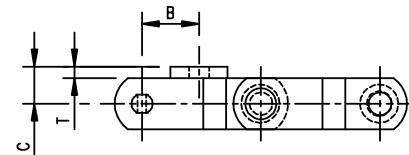
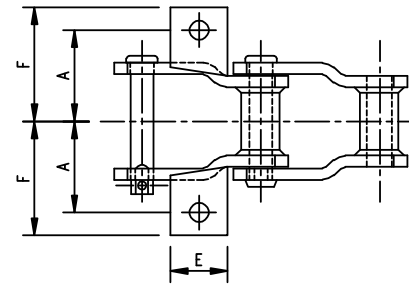

K1

COMMON MILL CHAIN ATTACHMENTS



K2

Chain No.	A	B	C	D	E	F	T	Weight Per Foot-Lbs.	Bolt Size
								Δ	
WR78	2	1 ⁵ / ₆₄	1 ³ / ₁₆	1 ¹ / ₈	2	2 ¹ / ₂	1/4	5.8	3/8
WH78	2	1 ⁵ / ₆₄	1 ³ / ₁₆	1 ¹ / ₈	2	2 ¹ / ₂	1/4	5.8	3/8
WH78HD	2	1 ³ / ₃₂	7/8	1 ¹ / ₈	2	2 ¹ / ₂	1/4	8.3	3/8
WR82	2 ¹ / ₈	1 ⁵ / ₁₆	1 ⁵ / ₁₆	1 ¹ / ₄	2 ¹ / ₄	2 ³ / ₄	5/16	7.1	3/8
WH82	2 ¹ / ₈	1 ⁵ / ₁₆	1 ⁵ / ₁₆	1 ¹ / ₄	2 ¹ / ₄	2 ³ / ₄	5/16	7.1	3/8
WH82HD	2 ¹ / ₈	1	1	1 ⁵ / ₁₆	2 ¹ / ₄	2 ³ / ₄	1/4	10.5	3/8
WH82XHD	2 ³ / ₈	1 ¹ / ₈	1 ¹ / ₈	1 ¹ / ₄	2 ¹ / ₄	2 ⁵ / ₁₆	3/8	12.4	3/8
WR124	2 ⁵ / ₈	1 ³ / ₁₆	1 ¹ / ₈	1 ¹⁵ / ₁₆	3	3 ¹ / ₂	3/8	12.1	3/8
WH124	2 ⁵ / ₈	1 ³ / ₁₆	1 ¹ / ₈	1 ¹⁵ / ₁₆	3	3 ¹ / ₂	3/8	12.1	3/8
WHX124	2 ⁵ / ₈	1 ³ / ₁₆	1 ¹ / ₈	1 ¹⁵ / ₁₆	3	3 ¹ / ₂	3/8	12.1	3/8
WH124HDSPC	2 ⁵ / ₈	1 ¹³ / ₁₆	1 ¹ / ₂	1 ¹⁵ / ₁₆	4	3 ³ / ₈	1/2	20.7	1/2
WR111+	3 ¹ / ₈	1 ¹³ / ₃₂	1 ¹ / ₄	2 ⁵ / ₁₆	3 ¹ / ₂	3 ⁷ / ₈	3/8	13.2	1/2
WH111+	3 ¹ / ₈	1 ¹³ / ₃₂	1 ¹ / ₄	2 ⁵ / ₁₆	3 ¹ / ₂	3 ⁷ / ₈	3/8	13.2	1/2
WR110	2 ¹ / ₃₂	2 ¹ / ₈	1 ¹ / ₈	1 ¹ / ₄	3	3 ⁵ / ₁₆	3/8	9.2	3/8
WH110	2 ¹ / ₃₂	2 ¹ / ₈	1 ¹ / ₈	1 ¹ / ₄	3	3 ⁵ / ₁₆	3/8	9.2	3/8
WR106	2 ⁵ / ₈	2 ¹ / ₈	1 ¹ / ₈	1 ¹ / ₄	3	3 ⁷ / ₁₆	3/8	9.3	3/8
WH106	2 ⁵ / ₈	2 ¹ / ₈	1 ¹ / ₈	1 ¹ / ₄	3	3 ⁷ / ₁₆	3/8	9.3	3/8
WHX106	2 ⁵ / ₈	2 ¹ / ₈	1 ¹ / ₈	1 ¹ / ₄	3	3 ⁷ / ₁₆	3/8	9.3	3/8
WR132	3 ³ / ₄	1 ²¹ / ₃₂	1 ¹ / ₂	2 ³ / ₄	4	4 ⁹ / ₁₆	1/2	19.0	1/2
WH132	3 ³ / ₄	1 ²¹ / ₃₂	1 ¹ / ₂	2 ³ / ₄	4	4 ⁹ / ₁₆	1/2	19.0	1/2
WHX132	3 ³ / ₄	1 ²¹ / ₃₂	1 ¹ / ₂	2 ³ / ₄	4	4 ⁹ / ₁₆	1/2	19.0	1/2
WH132HD	3 ³ / ₄	1 ²¹ / ₃₂	1 ¹ / ₂	2 ³ / ₄	4	4 ⁹ / ₁₆	1/2	21.2	1/2
WR150	3 ³ / ₄	1 ²¹ / ₃₂	1 ³ / ₄	2 ³ / ₄	4	4 ⁹ / ₁₆	1/2	21.6	1/2
WH150	3 ³ / ₄	1 ²¹ / ₃₂	1 ³ / ₄	2 ³ / ₄	4	4 ⁹ / ₁₆	1/2	21.6	1/2
WHX150	3 ³ / ₄	1 ²¹ / ₃₂	1 ³ / ₄	2 ³ / ₄	4	4 ⁹ / ₁₆	1/2	21.6	1/2
WH157	4	1 ²¹ / ₃₂	1 ³ / ₄	2 ³ / ₄	4	4 ⁹ / ₁₆	1/2	26.0	1/2
WHX157	4	1 ²¹ / ₃₂	1 ³ / ₄	2 ³ / ₄	4	4 ⁹ / ₁₆	1/2	26.0	1/2

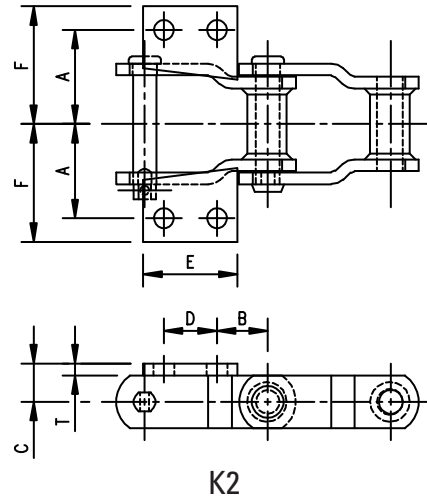

M1

Chain No.	A	B	T	Weight Per Foot-Lbs.
				Δ
WR132	1	3	1/2	16.6
WH132	1	3	1/2	16.6
WHX132	1	3	1/2	16.6
WH132HD	1	3	5/8	19.4
WR150	1	3 ¹ / ₂	1/2	19.2
WH150	1	3 ¹ / ₂	1/2	19.2
WHX150	1	3 ¹ / ₂	1/2	19.2
WHX155	1	3 ¹ / ₂	5/16	21.7
WH157	1	3 ¹ / ₂	5/8	23.6
WHX157	1	3 ¹ / ₂	5/8	23.6

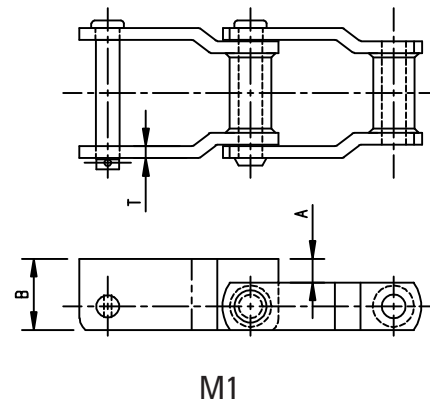



COMMON MILL CHAIN ATTACHMENTS

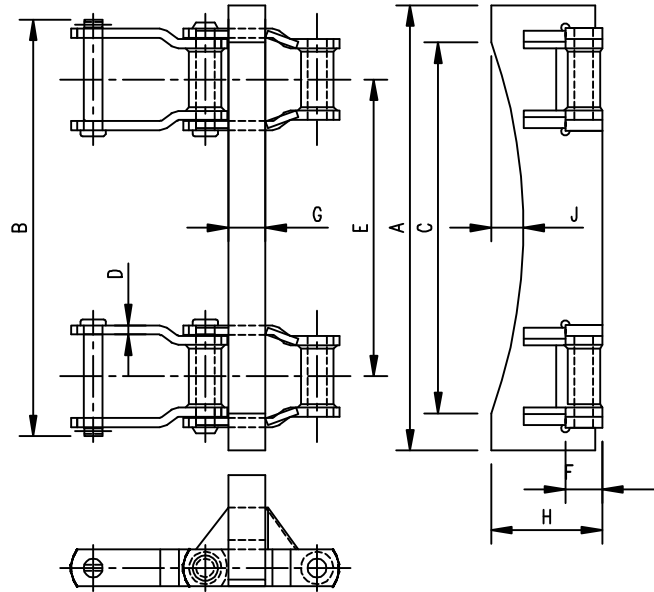

PC47

PC47

Chain No.	Assembly No.	Min. Spkt. Size	A	B	C	D	E	F	G	H	J	Weight Per Attach.-Lbs.
WH132	PC47-16	9T	18½	16¾	16	½	10	2	2	6	1¼	50
WHX132	PC47-16	9T	18½	16¾	16	½	10	2	2	6	1¼	50
WH132	PC47-20	9T	24	22⅞	20	½	16	2	2	6	1¼	60
WHX132	PC47-20	9T	24	22⅞	20	½	16	2	2	6	1¼	60

PETER FLIGHTS

Chain No.	X	Y	Z	Weight Per Pair-Lbs.
WR132	13	2	3½	8.0
WH132	13	2	3½	8.0
WHX132	13	2	3½	8.0
WH132HD	13	2	3½	8.0
WH157	13	2½	3½	9.0
WHX157	13	2½	3½	9.0

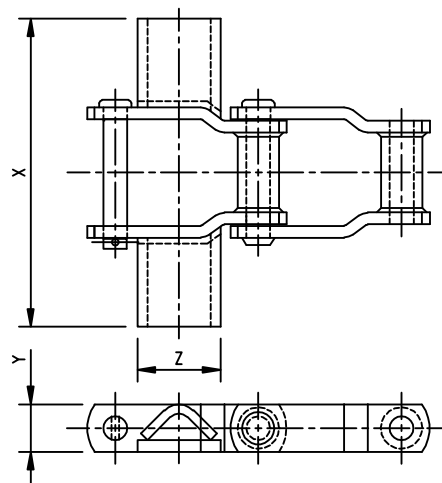

PETER FLIGHTS

COMMON MILL CHAIN ATTACHMENTS



RF2

Chain No.	B	C	F	T	Weight Per Foot-Lbs.
					Δ
WR78	1½	2⅝	3	¾	7.8
WH78	1½	2⅝	3	¾	7.8
WR124	2	3¼	4¼	¾	12.8
WH124	2	3¼	4¼	¾	12.8
WHX124	2	3¼	4¼	¾	12.8
WH124HDSPC	1⅝	3½	4¼	1	25.7

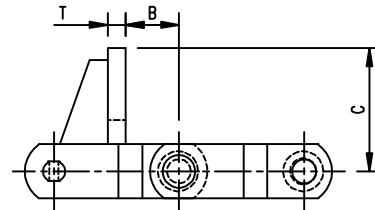
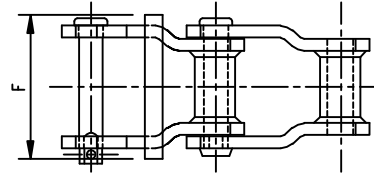

RF2

RF3

Chain No.	B	C	F	T	Weight Per Foot-Lbs.
					Δ
WR132	2	3½	4½	1	31.1
WH132	2	3½	4½	1	31.1
WHX132	2	3½	4½	1	31.1
WR150	2	3¾	4½	1	33.7
WH150	2	3¾	4½	1	33.7
WHX150	2	3¾	4½	1	33.7

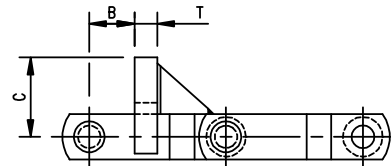
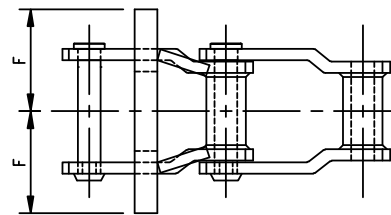

RF3

RF12

Chain No.	B	C	F	T	Weight Per Foot-Lbs.
					Δ
WR150	1⅝	5¼	6	1	48.9
WH150	1⅝	5¼	6	1	48.9
WHX150	1⅝	5¼	6	1	48.9
WH157	1½	5¼	6	1½	66.2
WHX157	1½	5¼	6	1½	66.2

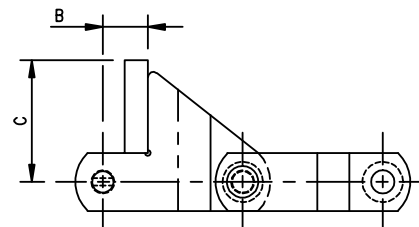
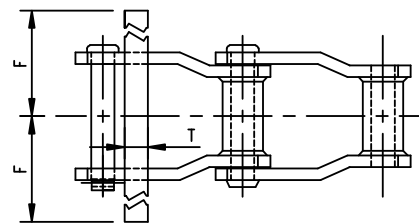

RF12



COMMON MILL CHAIN ATTACHMENTS

RF18

Chain No.	B	C	T	Weight Per Foot-Lbs.	
					Δ
WR150	1 ¹⁵ / ₁₆	4 ³ / ₄	1 ¹ / ₂		22.0
WH150	1 ¹⁵ / ₁₆	4 ³ / ₄	1 ¹ / ₂		22.0
WHX150	1 ¹⁵ / ₁₆	4 ³ / ₄	1 ¹ / ₂		22.0
WH157	1 ¹ / ₂	4 ³ / ₄	5 ⁵ / ₈		27.9
WHX157	1 ¹ / ₂	4 ³ / ₄	5 ⁵ / ₈		27.9

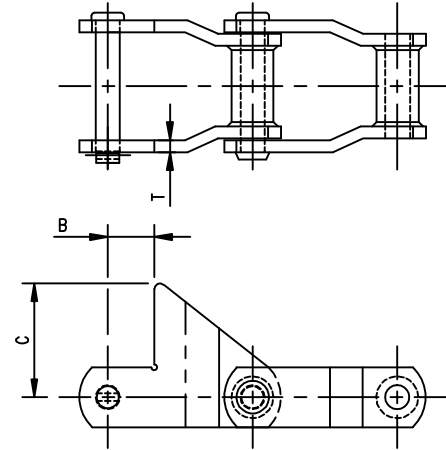

RF18

RR

Chain No.	B	C	F	T	Weight Per Foot-Lbs.	
						Δ
WR78	5 ⁵ / ₈	1 ¹⁵ / ₁₆	1	1 ¹ / ₄		4.9
WH78	5 ⁵ / ₈	1 ¹⁵ / ₁₆	1	1 ¹ / ₄		4.9
WR82	1 ¹⁵ / ₁₆	1 ³ / ₄	1 ¹ / ₈	1 ¹ / ₄		5.8
WH82	1 ¹⁵ / ₁₆	1 ³ / ₄	1 ¹ / ₈	1 ¹ / ₄		5.8
WR124	1 ¹ / ₂	1 ⁷ / ₈	1 ³ / ₈	3 ⁵ / ₈		9.5
WH124	1 ¹ / ₂	1 ⁷ / ₈	1 ³ / ₈	3 ⁵ / ₈		9.5
WHX124	1 ¹ / ₂	1 ⁷ / ₈	1 ³ / ₈	3 ⁵ / ₈		9.5

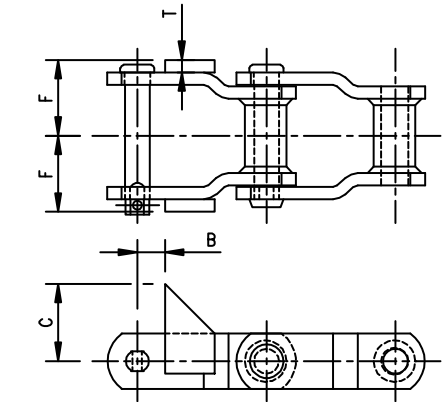

RR

S1

Chain No.	B	C	F	T	Weight Per Foot-Lbs.	
						Δ
WR124	1	3 ¹ / ₄	3 ³ / ₁₆	3 ⁵ / ₈		21.8
WH124	1	3 ¹ / ₄	3 ³ / ₁₆	3 ⁵ / ₈		21.8
WHX124	1	3 ¹ / ₄	3 ³ / ₁₆	3 ⁵ / ₈		21.8
WR132	1 ¹⁵ / ₁₆	5	5 ¹ / ₂	1 ¹ / ₂		28.5
WH132	1 ¹⁵ / ₁₆	5	5 ¹ / ₂	1 ¹ / ₂		28.5
WHX132	1 ¹⁵ / ₁₆	5	5 ¹ / ₂	1 ¹ / ₂		28.5
WH132HD	1 ¹⁵ / ₁₆	5	6	5 ⁵ / ₈		34.3
WR150	1 ¹⁵ / ₁₆	5 ¹ / ₄	5 ¹ / ₂	1 ¹ / ₂		34.3
WH150	1 ¹⁵ / ₁₆	5 ¹ / ₄	5 ¹ / ₂	1 ¹ / ₂		34.3
WHX150	1 ¹⁵ / ₁₆	5 ¹ / ₄	5 ¹ / ₂	1 ¹ / ₂		34.3
WH157	1 ¹ / ₂	3 ³ / ₄	6	5 ⁵ / ₈		36.2
WHX157	1 ¹ / ₂	3 ³ / ₄	6	5 ⁵ / ₈		36.2

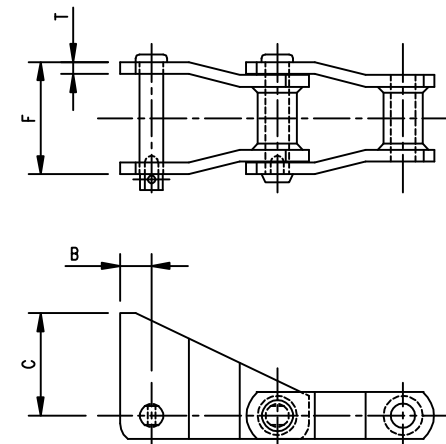

S1

NOTE: Specify one-piece or welded construction.

COMMON MILL CHAIN ATTACHMENTS

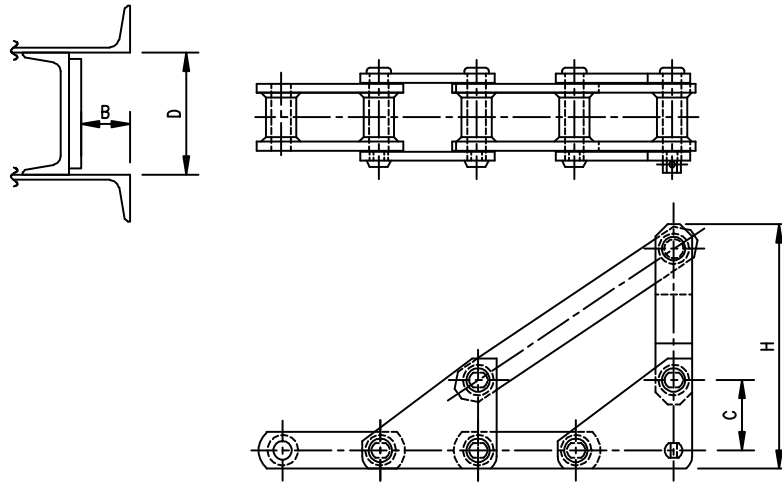

SIDE LIFT CHAIR - HINGED

SIDE LIFT CHAIR - HINGED

Chain No.	B	C	D	H	Pitches Per Assembly	Min. No. of Spkt. Teeth	Weight Per Chair-Lbs.
WR78	2	1 $\frac{3}{4}$	3 $\frac{1}{2}$	14	7	9	12.0
WH78	2	1 $\frac{3}{4}$	3 $\frac{1}{2}$	14	7	9	12.0
WR82	2	1 $\frac{3}{4}$	4	10	5	7	10.0
WH82	2	1 $\frac{3}{4}$	4	10	5	7	10.0
WR82	2	1 $\frac{3}{4}$	4	12	5	9	11.0
WH82	2	1 $\frac{3}{4}$	4	12	5	9	11.0
WH82HD	2	1 $\frac{3}{4}$	4 $\frac{1}{2}$	12	5	9	12.0
WH82HD	2	1 $\frac{3}{4}$	4 $\frac{1}{2}$	14	7	9	14.0
WH82XHD	2	1 $\frac{3}{4}$	4 $\frac{1}{2}$	10	5	7	11.0
WR124	2	2 $\frac{7}{8}$	5	10	4	7	11.0
WH124	2	2 $\frac{7}{8}$	5	10	4	7	11.0
WHX124	2	2 $\frac{7}{8}$	5	10	4	7	11.0
WR124	2	2 $\frac{7}{8}$	5	12	4	7	13.0
WH124	2	2 $\frac{7}{8}$	5	12	4	7	13.0
WHX124	2	2 $\frac{7}{8}$	5	12	4	7	13.0
WH124HDSPC	2	2 $\frac{1}{2}$	5 $\frac{1}{2}$	10	4	7	20.0
WH124XHD	2	3	6 $\frac{1}{4}$	10	4	7	26.0
WR132	2 $\frac{1}{2}$	3 $\frac{3}{4}$	6	12	4	8	40.0
WH132	2 $\frac{1}{2}$	3 $\frac{3}{4}$	6	12	4	8	40.0
WHX132	2 $\frac{1}{2}$	3 $\frac{3}{4}$	6	12	4	8	40.0

NOTE: B and D dimensions are recommended trough sizes.

NOTE: The height of chair depends on angle of lift and maximum diameter of logs.



COMMON MILL CHAIN ATTACHMENTS

UNIVERSAL ROOFTOP TRANSFER CHAIN

Chain No.	C	F	H	L	T	Weight Per Foot-Lbs.
						Δ
WR78	1 ¹ / ₁₆	2 ² / ₁₆	1 ³ / ₄	2 ⁷ / ₁₆	3 ³ / ₁₆	5.7
WH78	1 ¹ / ₁₆	2 ² / ₁₆	1 ³ / ₄	2 ⁷ / ₁₆	3 ³ / ₁₆	5.7

NOTE: Low tooth profile sprockets must be used with this chain.

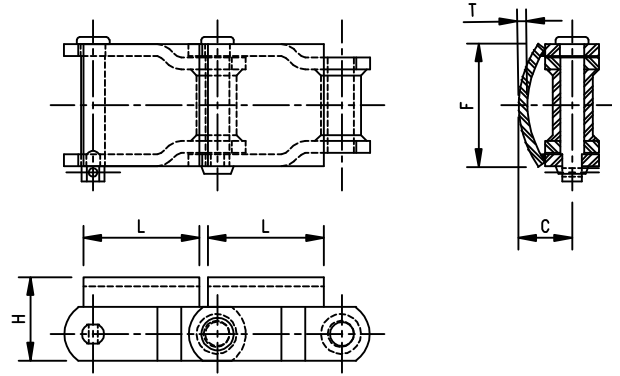

UNIVERSAL ROOFTOP TRANSFER CHAIN

RUBBER ROOFTOP TRANSFER CHAIN

Chain No.	C	F	H	L	Weight Per Foot-Lbs.
					Δ
WR78	2 ¹ / ₁₆	2 ³ / ₄	2 ⁵ / ₁₆	2 ⁷ / ₁₆	7.0
WH78	2 ¹ / ₁₆	2 ³ / ₄	2 ⁵ / ₁₆	2 ⁷ / ₁₆	7.0

NOTE: Low tooth profile sprockets must be used with this chain.

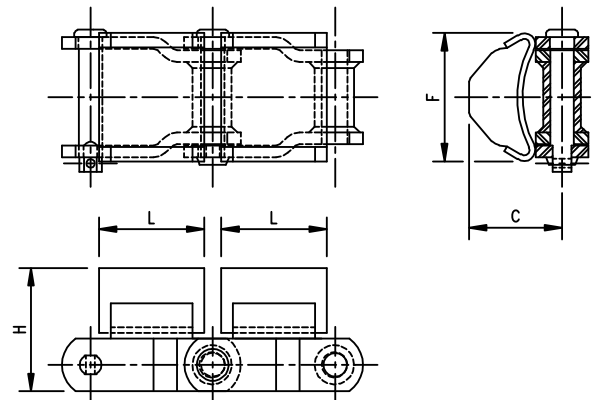

RUBBER ROOFTOP TRANSFER CHAIN

UHMW ROOFTOP TRANSFER CHAIN

Chain No.	C	F	H	L	Weight Per Foot-Lbs.
					Δ
WR78	1 ¹ / ₄	2 ⁵ / ₈	1 ⁹ / ₁₆	2 ¹ / ₂	4.8
WH78	1 ¹ / ₄	2 ⁵ / ₈	1 ⁹ / ₁₆	2 ¹ / ₂	4.8

NOTE: Low tooth profile sprockets must be used with this chain.

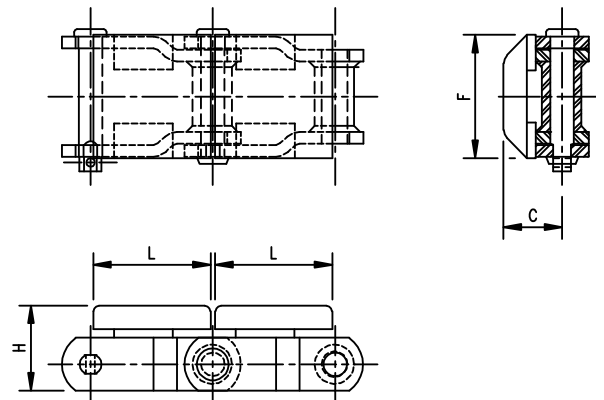

UHMW ROOFTOP TRANSFER CHAIN

Δ Weights of attachments coupled every pitch.

WELDED STEEL DRAG CHAINS



Welded steel drag chains are designed for drag conveyors where rugged and demanding environments exist. Webster's unique two-piece welded barrel offers better scraping action as well as double thickness at the wear points. The rugged welded construction permits high speeds, minimal lubrication and easy modification for application specific attachments. These chains are available in reverse barrel design.

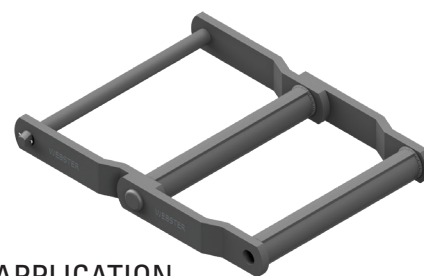

MATERIAL

Sidebars are medium carbon steel. Barrels are low carbon steel. Pins are medium carbon steel and are thru hardened for maximum chain life. The WDH chains also have thru hardened sidebars for greater strength and wear resistance. All parts can be furnished with additional heat treatment on request or as the operating environment requires.

ASSEMBLY

Welded steel drag chains are riveted construction. Cottered connecting pins are available on request as well as complete cottered construction.

INTERCHANGEABILITY

Welded steel drag chains are interchangeable with other standard makes of corresponding sizes and numbers.

APPLICATION

Welded steel drag chains are used in wood yards, paper mills and OSB plants to convey sawdust, bark and other scraps. They are also used to convey ash or machine chips in powerhouses or machining operations. They provide long life with very low maintenance.

OPERATION

Maximum chain speed depends upon size of sprockets. For Conveyor Service see Table 2, Section A.

Chain No.	Average Pitch Inches	Approx. Links in 10 Feet	Average Weight Per Ft. Lbs.	Average Ultimate Strength in Lbs.	Rated Working Load in Lbs.★	General Dimensions		
						Length of Bearing	℄ To Cotter End	℄ To Head or Rivet End
						X	K	J
WD102	5.000	24	11.8	51,000	8,500	7¼	4 ¹¹ / ₁₆	4 ⁷ / ₁₆
WDH102	5.000	24	11.8	60,000	10,000	7¼	4 ¹¹ / ₁₆	4 ⁷ / ₁₆
WD104	6.000	20	8.7	51,000	8,500	5½	3 ¹⁵ / ₃₂	3 ¹¹ / ₃₂
WDH104	6.000	20	8.7	60,000	10,000	5½	3 ¹⁵ / ₃₂	3 ¹¹ / ₃₂
WD110	6.000	20	12.0	51,000	8,500	10¾	6 ⁵ / ₃₂	5 ⁷ / ₃₂
WDH110	6.000	20	12.0	60,000	10,000	10¾	6 ⁵ / ₃₂	5 ⁷ / ₃₂
WD113	6.000	20	15.0	55,000	9,200	10¾	6 ⁵ / ₁₆	6 ¹ / ₈
WDH113	6.000	20	15.0	70,000	11,700	10¾	6 ⁵ / ₁₆	6 ¹ / ₈
WD120	6.000	20	19.4	70,000	11,700	10¾	6 ¹ / ₁₆	5 ¹ / ₂
WDH120	6.000	20	19.4	90,000	15,000	10¾	6 ¹ / ₁₆	5 ¹ / ₂
WDH520	6.000	20	21.0	103,000	17,200	10¾	6 ¹ / ₁₆	5 ¹ / ₂
WD112	8.000	15	9.8	51,000	8,500	10¾	5 ³ / ₃₂	5 ⁷ / ₃₂
WDH112	8.000	15	9.8	60,000	10,000	10¾	5 ³ / ₃₂	5 ⁷ / ₃₂
WD116	8.000	15	14.5	55,000	9,200	14 ¹ / ₈	7 ⁷ / ₃₂	7 ²³ / ₃₂
WDH116	8.000	15	14.5	69,000	11,500	14 ¹ / ₈	7 ⁷ / ₃₂	7 ²³ / ₃₂
WD118	8.000	15	19.8	70,000	11,700	14 ¹ / ₈	8 ¹ / ₁₆	8 ¹ / ₄
WDH118	8.000	15	19.8	90,000	15,000	14 ¹ / ₈	8 ¹ / ₁₆	8 ¹ / ₄
WD122	8.000	15	16.0	70,000	11,700	10¾	6 ¹ / ₁₆	5 ¹ / ₂
WDH122	8.000	15	16.0	90,000	15,000	10¾	6 ¹ / ₁₆	5 ¹ / ₂
WDH522	8.000	15	17.5	103,000	17,200	10¾	6 ¹ / ₁₆	5 ¹ / ₂
WD480	8.000	15	18.1	70,000	11,700	12¾	7 ¹ / ₈	7 ¹ / ₁₆
WDH480	8.000	15	18.1	90,000	15,000	12¾	7 ¹ / ₈	7 ¹ / ₁₆
WDH580	8.000	15	19.4	123,000	20,500	12¾	7 ¹ / ₂	7 ¹ / ₁₆
WDH680	8.000	15	21.4	134,000	22,300	13	7 ¹ / ₈	7 ¹ / ₁₆

NOTE: Recommended minimum drag chain sprocket diameter is three times the pitch.

NOTE: Supplied in 10' strands but available up to 40' upon request at no additional cost.

★ Subject to Service Factor see Table 9 and Speed Factor Table 10, Section A, in Webster #400 Master Catalog.



WELDED STEEL DRAG CHAINS

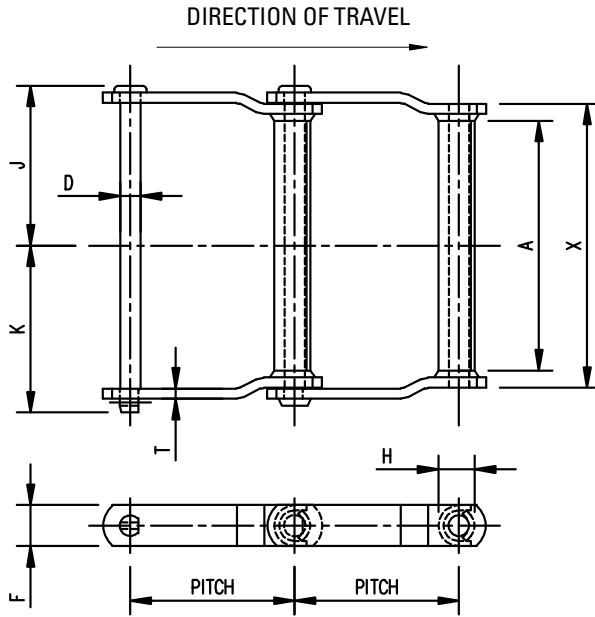

Abbreviations of Material and Treatment

L.C. Low Carbon
M.C. Medium Carbon
M.C.H.T. Medium Carbon, Heat Treated

Chain No.	Pins		Sidebars			Barrels		Max. Spkt. Width A	Common Attachment Numbers
	Dia.	Material	Thk.	Height	Material	Outside Dia.	Material		
	D		T	F		H			
WD102	3/4	M.C.H.T.	3/8	1 1/2	M.C.	1 1/2	L.C.	6 1/4	C1, C4, RR, WING
WDH102	3/4	M.C.H.T.	3/8	1 1/2	M.C.H.T.	1 1/2	L.C.	6 1/4	C1, C4, RR, WING
WD104	3/4	M.C.H.T.	3/8	1 1/2	M.C.	1 1/2	L.C.	4	C1, C4, RR, WING
WDH104	3/4	M.C.H.T.	3/8	1 1/2	M.C.H.T.	1 1/2	L.C.	4	C1, C4, RR, WING
WD110	3/4	M.C.H.T.	3/8	1 1/2	M.C.	1 1/2	L.C.	9	C1, C3, C4, RR, WING
WDH110	3/4	M.C.H.T.	3/8	1 1/2	M.C.H.T.	1 1/2	L.C.	9	C1, C3, C4, RR, WING
WD113	7/8	M.C.H.T.	1/2	1 1/2	M.C.	1 1/2	L.C.	9	C3, C4, RR, WING
WDH113	7/8	M.C.H.T.	1/2	1 1/2	M.C.H.T.	1 1/2	L.C.	9	C3, C4, RR, WING
WD120	7/8	M.C.H.T.	1/2	2	M.C.	2	L.C.	8 1/2	C3, WING
WDH120	7/8	M.C.H.T.	1/2	2	M.C.H.T.	2	L.C.	8 1/2	C3, WING
WDH520	1	M.C.H.T.	1/2	2	M.C.H.T.	2	L.C.	8 1/2	
WD112	3/4	M.C.H.T.	3/8	1 1/2	M.C.	1 1/2	L.C.	9	C1, C4, RR, WING
WDH112	3/4	M.C.H.T.	3/8	1 1/2	M.C.H.T.	1 1/2	L.C.	9	C1, C4, RR, WING
WD116	3/4	M.C.H.T.	3/8	1 3/4	M.C.	1 3/4	L.C.	12 1/4	C1, C3, C4, RR, WING
WDH116	3/4	M.C.H.T.	3/8	1 3/4	M.C.H.T.	1 3/4	L.C.	12 1/4	C1, C3, C4, RR, WING
WD118	7/8	M.C.H.T.	1/2	2	M.C.	2	L.C.	13 1/4	C3, RR, WING
WDH118	7/8	M.C.H.T.	1/2	2	M.C.H.T.	2	L.C.	13 1/4	C3, RR, WING
WD122	7/8	M.C.H.T.	1/2	2	M.C.	2	L.C.	8 1/2	WING
WDH122	7/8	M.C.H.T.	1/2	2	M.C.H.T.	2	L.C.	8 1/2	WING
WDH522	1	M.C.H.T.	1/2	2	M.C.H.T.	2	L.C.	8 1/2	
WD480	7/8	M.C.H.T.	1/2	2	M.C.	2	L.C.	11	C1, C3, C4, RR, WING
WDH480	7/8	M.C.H.T.	1/2	2	M.C.H.T.	2	L.C.	11	C1, C3, C4, RR, WING
WDH580	1	M.C.H.T.	1/2	2	M.C.H.T.	2	L.C.	11	C1, RR
WDH680	1	M.C.H.T.	3/8	2	M.C.H.T.	2	L.C.	11	RR, WING

WELDED STEEL HEAVY-DUTY DRAG CHAINS



Welded steel heavy-duty drag chains are manufactured with larger, heftier parts with extra surface area for longer service life. Their rugged welded construction permits higher speeds, minimal lubrication and easy modification for application specific attachments.

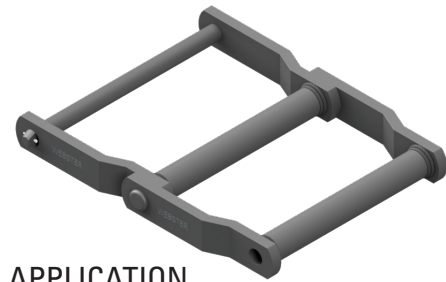

MATERIAL

Sidebars, barrels and pins are medium carbon steel which has been thru hardened for maximum chain life. All components can be furnished with additional heat treatment on request or as the operating environment requires.

ASSEMBLY

Welded steel heavy-duty drag chains are riveted construction. Cottered connecting pins are available on request as well as complete cottered construction.

INTERCHANGEABILITY

Welded steel heavy-duty drag chains are interchangeable with other standard makes of corresponding sizes and numbers.

APPLICATION

Welded steel heavy-duty drag chains can be used anywhere that our standard welded steel drag chains are used. This includes wood yards, paper mills, OSB plants and powerhouses. They provide longer life with very low maintenance.

OPERATION

Maximum chain speed depends upon size of sprockets. For Conveyor Service see Table 2, Section A.

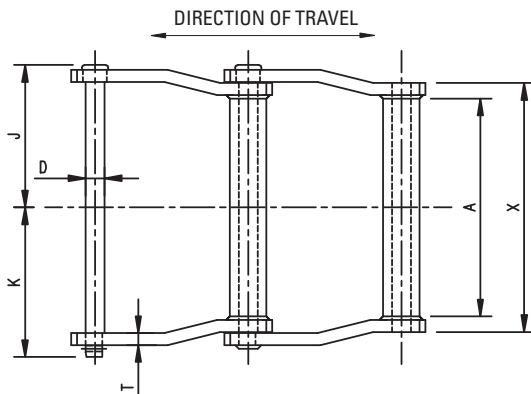

Abbreviations of Material and Treatment

M.C.H.T. Medium Carbon, Heat Treated

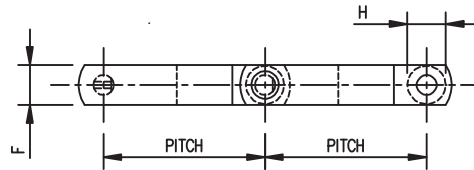

Chain No.	Average Pitch Inches	Approx. Links in 10 Feet	Average Weight Per Ft. Lbs.	Average Ultimate Strength in Lbs.	Rated Working Load in Lbs.★	General Dimensions		
						Length of Bearing	☉ To Cotter End	☉ To Head or Rivet End
						X	K	J
WDH118HD	8.00	15	24.5	134,000	22,300	15%	8 ¹¹ / ₁₆	8 ¹ / ₂
WDH120HD	6.00	20	24.5	134,000	22,300	10%	6 ⁵ / ₁₆	6 ¹ / ₂
WDH122HD	8.00	15	20.5	134,000	22,300	10%	6 ⁵ / ₁₆	6 ¹ / ₂
WDH480HD	8.00	15	22.4	134,000	22,300	13	7%	7 ¹ / ₁₆





★ See page A-12 for Service Factor, Table 9, and page A-13 for Speed Factor, Tables 10 & 11 in Webster #400 Master Catalog.

Chain No.	Pins		Sidebars			Barrels		Max. Spkt. Width	Common Attachment Numbers
	Dia.	Material	Thk.	Height	Material	Outside Dia.	Material		
	D		T	F		H			
WDH118HD	1	M.C.H.T.	3/8	2	M.C.H.T.	2	M.C.H.T.	13 ³ / ₄	
WDH120HD	1	M.C.H.T.	3/8	2	M.C.H.T.	2	M.C.H.T.	8 ¹ / ₂	
WDH122HD	1	M.C.H.T.	3/8	2	M.C.H.T.	2	M.C.H.T.	8 ¹ / ₂	
WDH480HD	1	M.C.H.T.	3/8	2	M.C.H.T.	2	M.C.H.T.	11	

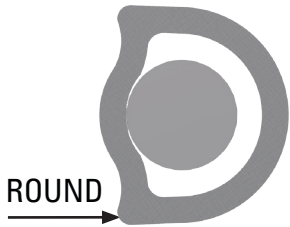
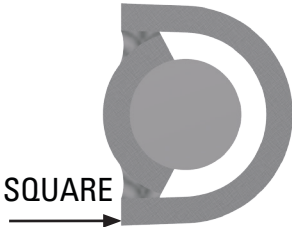
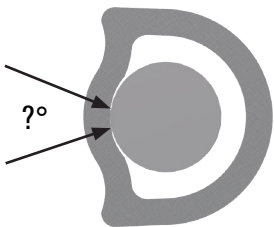
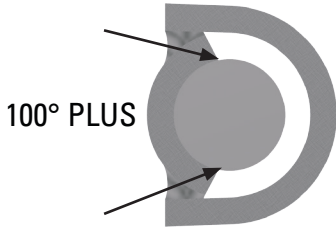

BARREL COMPARISON

For longer life, look to Webster's two-piece welded barrel.

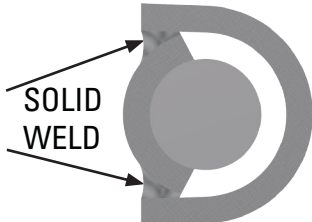
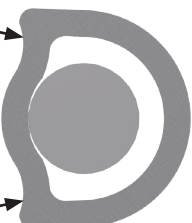
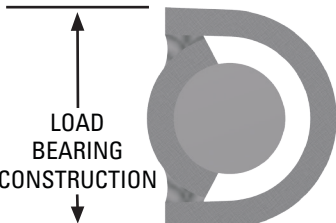
CROSS SECTION OF A DRAG CHAIN BARREL		WHY THE EXCLUSIVE WEBSTER HEAVY-DUTY, TWO-PIECE WELDED BARREL IS YOUR BEST BUY.
Competitor's Formed Tube Barrel	Webster's Two-Piece Welded Barrel	
		<p>SCRAPING ACTION</p> <p>The square edge runs flat in the conveyor and will not ride up on the product. This ensures product conveyance despite moisture content.</p>
		<p>FULL LOAD DISTRIBUTION ON PIN</p> <p>The Webster two-piece welded barrel wraps around the pin insuring fixed, positive contact with the barrel. The wear is distributed over 100° or more of the pin diameter.</p>
<p><u>THIN</u></p>  <p><u>LIGHT</u></p>	<p><u>THICK</u></p>  <p><u>RUGGED</u></p>	<p>DOUBLE THICKNESS, TOP AND BOTTOM</p> <p>This provides protection at the wear points for longer life even in the harshest loading applications.</p>
<p>THIN WALL</p> 	<p>SOLID WELD</p> 	<p>RIGID TWO-PIECE WELDED CONSTRUCTION</p> <p>The Webster barrel wraps around the pin, which reduces flexing. This minimizes fatigue failures and increases pin life.</p>
<p>STRESS</p>  <p>STRESS</p>	<p>LOAD BEARING CONSTRUCTION</p> 	<p>IMPACT RESISTANCE</p> <p>The structure of the Webster two-piece welded barrel can take more vertical load impact without weakening the barrel or causing barrel deformation, which in turn eliminates binding between the barrel and the pin.</p>

COMMON DRAG CHAIN ATTACHMENTS



RR

Chain No.	B	F	G	T	Weight Per Pair-Lbs.
WD102/WDH102	3	9 $\frac{5}{8}$	2 $\frac{1}{4}$	$\frac{3}{8}$	0.6
WD104/WDH104	3 $\frac{1}{2}$	7	2 $\frac{1}{4}$	$\frac{3}{8}$	0.6
WD110/WDH110	3 $\frac{1}{2}$	12	2 $\frac{1}{4}$	$\frac{3}{8}$	0.6
WD112/WDH112	3 $\frac{1}{2}$	12	2 $\frac{1}{4}$	$\frac{3}{8}$	0.6
WD113/WDH113	3 $\frac{1}{2}$	12 $\frac{5}{8}$	2 $\frac{1}{4}$	$\frac{3}{8}$	0.6
WD116/WDH116	4 $\frac{3}{4}$	15 $\frac{3}{4}$	2 $\frac{5}{8}$	$\frac{3}{8}$	0.9
WD118/WDH118	4 $\frac{3}{4}$	17	3	$\frac{1}{2}$	1.5
WD480/WDH480	4 $\frac{3}{4}$	14 $\frac{7}{8}$	3	$\frac{1}{2}$	1.5
WDH580	4 $\frac{3}{4}$	14 $\frac{7}{8}$	3	$\frac{1}{2}$	1.5
WDH680	4 $\frac{3}{4}$	15 $\frac{3}{8}$	3	$\frac{1}{2}$	1.5

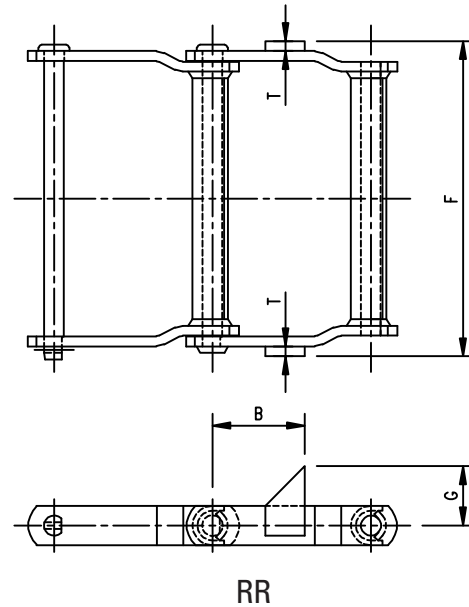

C1

Chain No.	B	F	G	T	Weight Per Attach.-Lbs.
WD102/WDH102	$\frac{3}{8}$	6 $\frac{1}{2}$	2 $\frac{1}{4}$	$\frac{3}{8}$	1.2
WD104/WDH104	$\frac{3}{8}$	4 $\frac{1}{8}$	2 $\frac{1}{4}$	$\frac{3}{8}$	0.8
WD110/WDH110	$\frac{3}{8}$	9 $\frac{1}{8}$	2 $\frac{1}{4}$	$\frac{3}{8}$	1.6
WD112/WDH112	$\frac{3}{8}$	9 $\frac{1}{8}$	2 $\frac{1}{4}$	$\frac{3}{8}$	1.6
WD116/WDH116	$\frac{3}{8}$	12 $\frac{1}{8}$	2 $\frac{3}{8}$	$\frac{3}{8}$	2.2
WD480/WDH480	$\frac{1}{2}$	11 $\frac{3}{4}$	2 $\frac{3}{4}$	$\frac{1}{2}$	3.1
WDH580	$\frac{1}{2}$	11 $\frac{3}{4}$	2 $\frac{1}{2}$	$\frac{1}{2}$	2.6

C3

Chain No.	B	F	G	T	Weight Per Attach.-Lbs.
WD110/WDH110	$\frac{3}{8}$	9 $\frac{1}{8}$	3	$\frac{3}{8}$	2.4
WD113/WDH113	$\frac{1}{2}$	9 $\frac{1}{8}$	3	$\frac{1}{2}$	3.1
WD116/WDH116	$\frac{3}{8}$	12 $\frac{7}{8}$	3	$\frac{3}{8}$	3.1
WD118/WDH118	$\frac{1}{2}$	13 $\frac{3}{4}$	3	$\frac{1}{2}$	3.9
WD120/WDH120	$\frac{1}{2}$	8 $\frac{5}{8}$	3	$\frac{1}{2}$	2.6
WD480/WDH480	$\frac{1}{2}$	11 $\frac{3}{4}$	3	$\frac{1}{2}$	3.5

C4

Chain No.	B	F	G	T	Weight Per Attach.-Lbs.
WD102/WDH102	$\frac{3}{8}$	6 $\frac{1}{2}$	3 $\frac{3}{4}$	$\frac{3}{8}$	2.2
WD104/WDH104	$\frac{3}{8}$	4 $\frac{1}{8}$	3 $\frac{3}{4}$	$\frac{3}{8}$	1.5
WD110/WDH110	$\frac{3}{8}$	9 $\frac{1}{8}$	3 $\frac{3}{4}$	$\frac{3}{8}$	3.1
WD112/WDH112	$\frac{3}{8}$	9 $\frac{1}{8}$	3 $\frac{3}{4}$	$\frac{3}{8}$	3.1
WD113/WDH113	$\frac{3}{8}$	9 $\frac{1}{8}$	4 $\frac{1}{4}$	$\frac{1}{2}$	5.4
WD116/WDH116	$\frac{3}{8}$	12 $\frac{1}{8}$	4 $\frac{1}{8}$	$\frac{3}{8}$	5.6
WD480/WDH480	$\frac{1}{2}$	11 $\frac{3}{4}$	5	$\frac{1}{2}$	7.0

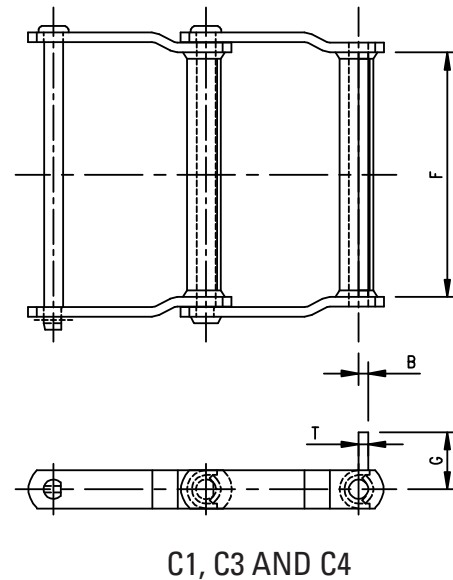



COMMON DRAG CHAIN ATTACHMENTS

WING

Chain No.	F	B	T	Weight Per Pair-Lbs.
WD104/WDH104	11	2½	¾	1.8
WD104/WDH104	12	2½	¾	2.1
WD102/WDH102	13¼	1¾	¾	1.8
WD102/WDH102	14¾	1¾	¾	2.2
WD110/WDH110	15	2½	¾	1.4
WD120/WDH120	15	2¾	½	2.4
WD110/WDH110	16	1¾	¾	1.8
WD110/WDH110	17	2½	¾	2.0
WD112/WDH112	17	3¼	¾	2.0
WD113/WDH113	17	2½	¾	2.4
WD120/WDH120	17	2½	½	3.6
WD122/WDH122	17	3	½	3.6
WD480/WDH480	17	3	½	2.1
WD480/WDH480	18	3¼	½	2.6
WDH680/WDH680	18	2½	½	2.5
WD110/WDH110	19	2½	¾	2.7
WD120/WDH120	19	2½	½	4.6
WD480/WDH480	19	3	½	3.2
WD110/WDH110	20	2½	¾	3.0
WD480/WDH480	20	3	½	3.8
WD110/WDH110	21	2½	¾	3.3
WD480/WDH480	21	3	½	4.4
WD110/WDH110	22	1¾	¾	3.7
WD116/WDH116	22	3	¾	2.9
WD118/WDH118	22	3	½	3.7
WD120/WDH120	22	2½	½	6.2
WD122/WDH122	22	3	½	6.4
WD480/WDH480	22	3	½	5.0
WDH680	22	2½	½	4.9
WD110/WDH110	23	1¾	¾	4.0
WD110/WDH110	24	1¾	¾	4.3
WD112/WDH112	24	3	¾	4.3
WD480/WDH480	24	3	½	6.0
WD118/WDH118	25	2¾	½	5.6
WD116/WDH116	28	3	¾	5.1
WD480/WDH480	26	3	½	7.2
WD480/WDH480	28	2¾	½	8.4
WD116/WDH116	29	3	¾	5.9
WD118/WDH118	30	2¾	½	8.2
WD480/WDH480	30	2¾	½	9.5
WD480/WDH480	32	2¾	½	10.5

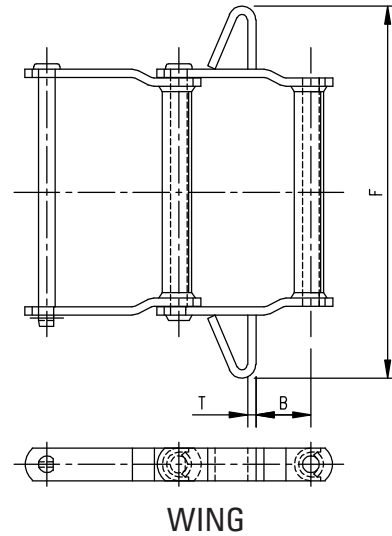



Webster Sprockets are designed and manufactured according to the same core quality standards as Webster chain. Each sprocket is carefully designed by Webster's experienced engineering team, and is then manufactured with the highest quality USA made medium carbon steel by skilled American laborers.

Pairing Webster Chain and Sprockets on your application, ensures that your conveyor is performing at the highest level of productivity, reliability and service.

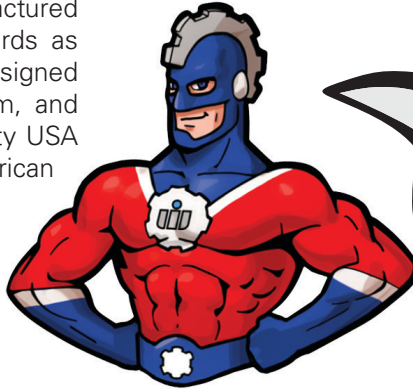

WHY WEBSTER SPROCKETS?

- Purchase with Chain Double Your Warranty
- Industry Best Delivery
- Easy Customization
- Highest Quality
- Qualifies for Free Freight
- Made In The USA

WEBSTER'S SPROCKET DESIGN

Webster Sprockets are designed and manufactured per the ASME/ANSI specification. The sprocket selection and design depend on the chain and the customer's application. Webster's standard design utilizes low profile teeth to ensure the sprocket does not interfere with the chain and its attachments. Various material options and numerous teeth profiles, plating options and special features are available upon request. Please consult our engineering department for any special needs.

WEBSTER SPROCKET FEATURES

WEAR LINE INDICATORS

Indicate when it is time to replace the sprockets. When the sprocket face is worn to the scribed line the sprocket needs replaced along with the chain. Wear line indicators are an easy visual tool to help guide best practices in chain sprocket and conveyor operations.

LIFTING HOLE

Are positioned directly above the key and provide easy placement of a lifting strap, rod or other device to make sprocket installation easier and safer. Lifting holes are provided on all sprockets unless restricted by space.

FLAME HARDENED TEETH

Webster's automated, computer-controlled hardening process increases wear resistance and sprocket longevity. Our hardening process allows us to achieve precise hardness levels. All Webster sprockets have a minimum 40 Rc in all critical wear areas and utilize USA made 1045 steel plate.

LIGHTENING HOLES

Provided on some sprockets so that weight can be reduced. Lightening holes come standard on most bucket elevator sprockets and upon customer request unless restricted by space.

MACHINED CHAMFERED TEETH

All teeth are machine chamfered at a 15 degree angle on each side of the tooth to ensure proper chain and sprocket engagement. This reduces the likelihood of sprocket and sidebar scrubbing or improper chain engagement resulting in premature, unexpected failures.

LOCKING HEAD FEATURE

Split sprockets come with a locking head feature which allow for ease of assembly. The hub holds the head of the bolt against its flat edge. This allows one tool and one person to easily torque the locking nut in place securing the sprocket to the shaft.

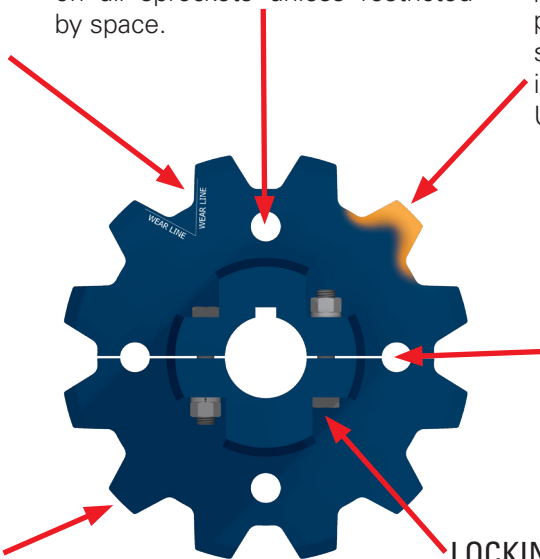



SPROCKET NOMENCLATURE

NUMBER OF TEETH

The actual count of the sprocket teeth which engage the chain.

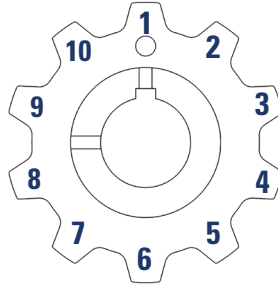

PITCH DIAMETER (P.D.)

The diameter of the circle that a chain makes when it wraps or chords around a sprocket. This measurement is taken from the center of a chain pin across the sprocket to the center of the opposite chain pin.

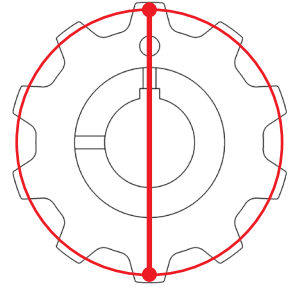

BORE DIAMETER

The diameter of the circle of the central hole in the sprocket or hub.

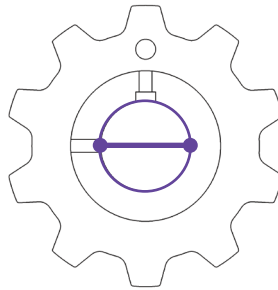

OUTSIDE DIAMETER (O.D.)

The outside diameter is the measurement from the tip of one sprocket tooth to the corresponding sprocket tooth directly opposite.

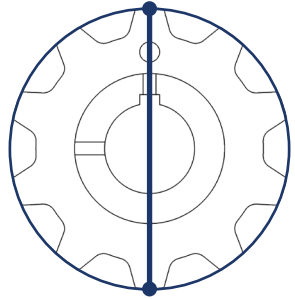

HUB OUTSIDE DIAMETER (H.O.D.)

The outside diameter of the hub which is welded to the sprocket plate.

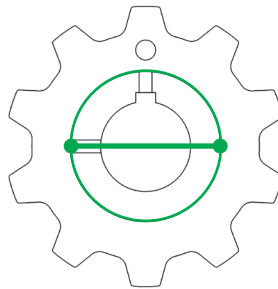

BOTTOM DIAMETER (B.D.)

The diameter of the circle that is the lowest pocket point to the lowest pocket point directly opposite.

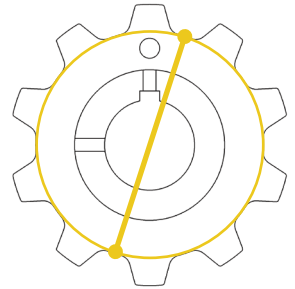

LENGTH THROUGH BORE (L.T.B.)

The length of the hub that the shaft passes through and contacts. This is designed for torque transmission and stability.

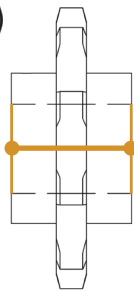

ROOT DIAMETER

The diameter of a circle a chain makes as it sits in the bottom of the pocket. This measurement is taken from the bottom of the chain round component (roller, bushing or barrel) to the opposite round component.

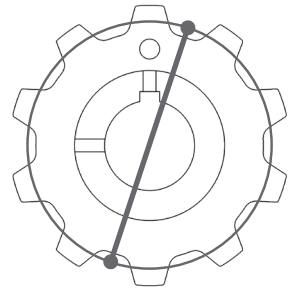

WORKING FACE

The straight line of a sprocket tooth where the chains engages and wears against. This is designed for maximum chain elongation but also short enough to avoid interferences.

PITCH LINE CLEARANCE

The measurement of the elongated pocket shapes. Designed to allow slight material build up without interfering in chain articulation around a sprocket.



MATERIAL

FLAME CUT, FLAME HARDENED SPROCKETS AND TRACTION WHEELS

Flame cut, flame hardened sprockets and traction wheels are manufactured to a standard hardness of 40 Rc minimum at the surface. The inherent strength and flame hardened teeth of these sprockets provide maximum service in abrasive applications with high shock loading. The versatility of flame cut sprockets allows for specialized designs for a variety of customer requirements.

STAINLESS STEEL SPROCKETS

Stainless steel sprockets are available for extremely harsh, abrasive or highly corrosive applications. Webster offers multiple grades of stainless steel including 300 and 400 series.

ARMORMAX SPROCKETS

For severe duty applications and the demanding requirements for bucket elevators, Webster offers ArmorMAX Sprockets. These sprockets have superior hardness specifications. All ArmorMAX Sprockets are hardened to 55 Rc minimum at the surface. All Webster Sprockets can be offered with ArmorMAX hardening.



CONSTRUCTION



SOLID

Solid sprockets are the standard body option. This sprocket is manufactured in one piece and will need to be slid on the shaft during installation in the conveyor.

SPLIT

Split sprockets are manufactured in two pieces. They are used where ease of installation or replacement is required without disturbing the shaft, bearings or other sprockets.



SEGMENTAL

Segmental sprockets have removeable segments of teeth (sprockets) or rims (traction wheels). Rim segments may be replaced without removing the chain by rotating the sprocket until one segment is free from the chain, replacing it, then rotating to the next segment. Segmental sprockets and traction wheels can be furnished with solid or split bodies. Segments should be replaced in complete sets to ensure proper fit.

TYPE

- Traction Wheels
- Drum Sprockets
- Flanged Rim Drum Sprockets
- Mud Relief Sprockets
- Hunting (Walking) Tooth Sprockets
- Gap Tooth Sprockets
- Chain Saver Sprockets
- Clinker Drag Chain Sprockets



TO SEE THE FULL
SPROCKETS
CATALOG,
SCAN HERE



WEBSTER VIBRATING CONVEYOR DESIGN

WEBSTER VIBRATING CONVEYORS

Webster vibrating conveyors have been the leader in servicing sawmills and other forest product applications for over 40 years. Our conveyors are utilized extensively to effectively convey bark, chips, edgings, sawdust, slabs and trim blocks. Webster conveyors are designed to provide spill- and jam-free operation of the long and irregularly shaped sizes of waste common to the forest products industry. The smooth, continuous trough of our conveyors handles this waste with minimal operational maintenance, providing years of reliable service. In addition, Webster conveyors can be fitted with screens to remove small particles from the waste stream; fiberglass or stainless steel section to allow for metal detection or removal; oversize pans, which are designed to catch or turn materials effectively; and transition chutes and spouts to seamlessly feed waste into other conveyors, chippers or hogs. Webster's vibrating conveyors are available in two models, flat spring and coil spring, and both are effective solutions for the tough demands of the forest products industry.

FS SERIES

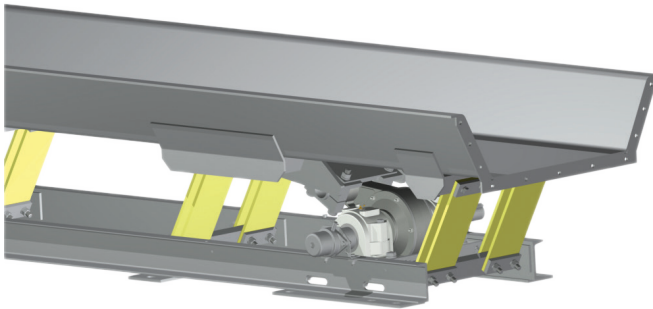

COILWEB

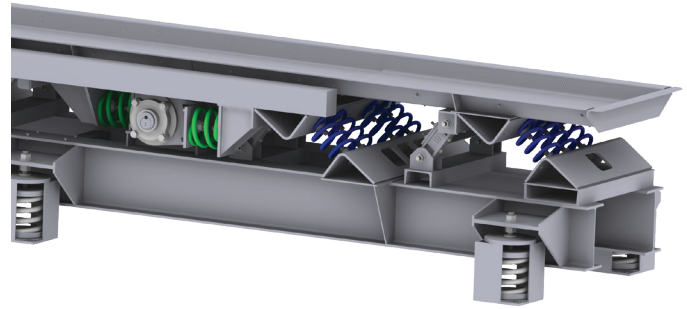

WEBSTER VIBRATING CONVEYOR DESIGN BENEFITS

- Can readily handle hot or abrasive materials.
- Handles fragile materials (potato chips, cereal flakes, etc.) without degradation.
- Smooth continuous trough – no pockets for material to accumulate in or jamming of material.
- Conveyor is normally self-cleaning.
- No return strand to carry over.
- Simple construction with minimum number of moving parts.
- Moving parts are not in contact with material.
- Minimum safety hazard to persons working on or near conveyor.
- Pan is usually widest part of conveyor.
- Pan is easily enclosed, even at transfer points.
- Discharge end may be tapered to spread material.
- Abrupt discharge.
- Little headroom required for change in direction or discharge to other equipment.
- Problems at discharge or transfer points are minimized by lower conveying speed, low headroom and abrupt discharge. If problems do occur, they are easily corrected by modifying end of pan.
- Multiple discharge points are possible.
- Conveyor can perform special operations (scalping, dedusting, magnetic separation, lump breaking, washing, heating, cooling, drying, etc.) while conveying.
- Unit machines have been completely assembled and tested at the factory, allowing for minimum work and time at installation.



TO SEE THE FULL
VIBRATING CONVEYORS
CATALOG,
SCAN HERE

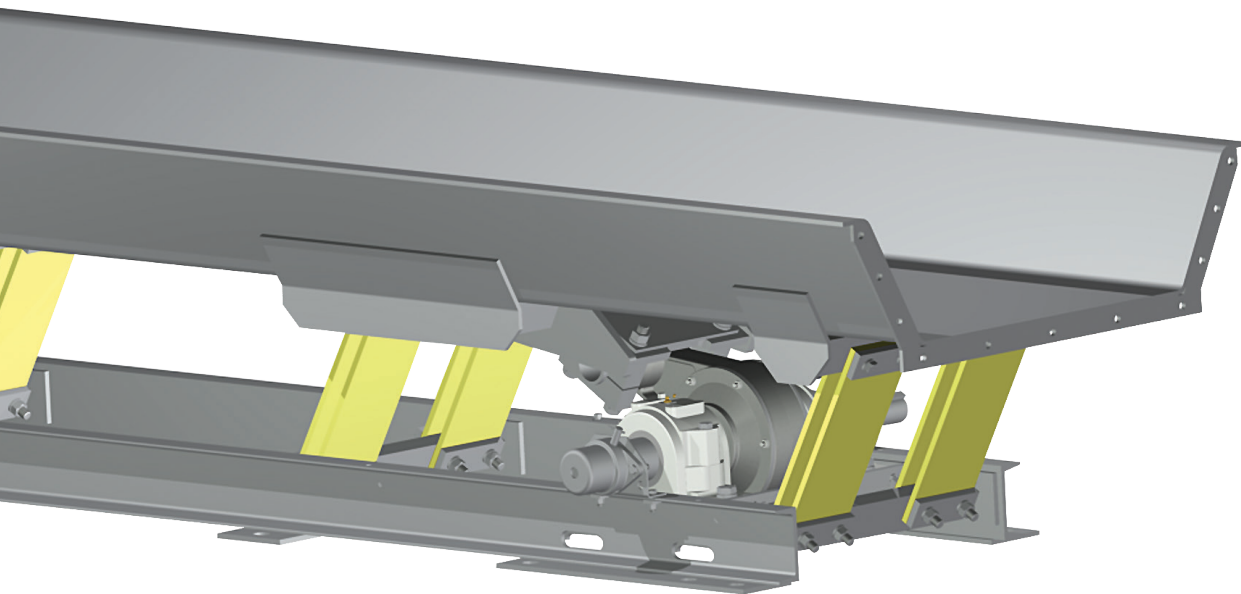

This series includes the FSL, a light-duty, low-headroom conveyor for small-particle, low-capacity applications; the FSM, a medium-duty conveyor for small-particle, high-capacity applications; and the FSH, a medium- to heavy-duty conveyor for a larger particle size and increased capacity applications. All FS conveyors incorporate the natural frequency principle, controlled vibration, positive eccentric drive and standardized sectional construction. They provide a rugged and economical answer to many bulk material conveying and processing jobs.

FS series vibrating conveyors will convey granular or lump material ranging in size from minus 100 mesh to any lump size which will fit into the pan. They can handle

weight from several pounds to several hundred pounds per cubic foot, and are particularly effective for conveying heavy, sharp or abrasive materials that are not readily handled on other types of conveyors. They also may be adapted to processing operations, such as inspecting, sorting, screening, washing, dewatering, heating, cooling and drying.

The following pages detail the dimensions of our standard pan sizes. Other pan sizes and shapes are available. FS series vibrating conveyors can be custom-designed for your application.

MATERIAL

FS series vibrating conveyors incorporate fabricated steel pans, a natural frequency spring system, a positive eccentric drive powered by an electric motor and v-belts on an adjustable base.

ASSEMBLY

Standard drive and extension sections are delivered in preassembled sections. Jig-figtured, bolted pan flanges make field assembly easy.

APPLICATION

FS series vibrating conveyors are used where horizontal or shallow incline conveying is required. They handle a wide variety of bulk materials, from powders to solids. They are designed to handle fragile, sharp and irregularly shaped materials, and are primarily used in the forest products, stamping, food, grain and chemical industries.



COILWEB® SERIES VIBRATING CONVEYORS

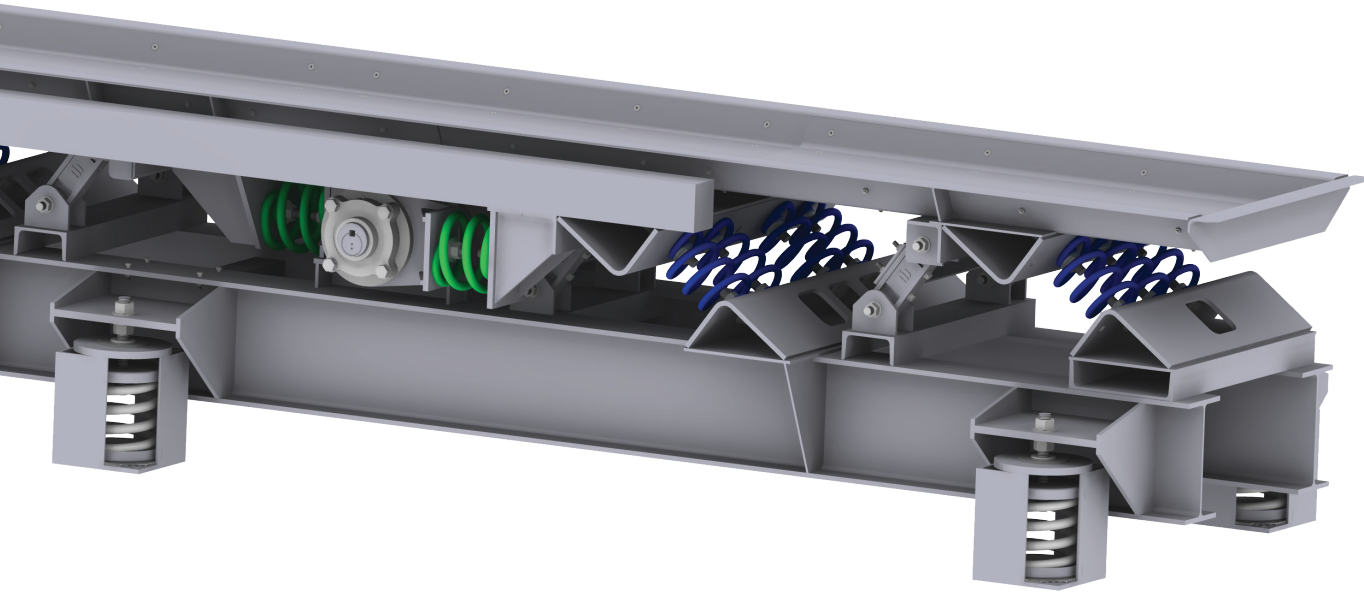

This series of heavy duty service conveyors includes the CoilWeb® and CoilWeb® LS models, both with a broad range of capabilities for tough conveying applications. Features of the CoilWeb® series include use of the natural frequency principle utilizing coil springs, controlled vibration, semipositive coil spring drive and standardized spring and rocker arm components. They provide a heavy-duty solution for rigorous bulk material handling and processing jobs.

CoilWeb® vibrating conveyors will convey granular or lump materials ranging in size from minus 100 mesh to any lump size which will fit into the pan. These conveyors can handle density ranging from several pounds to several

hundred pounds per cubic foot. CoilWeb® is designed for heavily loaded hot or abrasive material applications which are not readily handled by other conveyors. CoilWeb® conveyors may also be adapted for processing operations, such as screening, sorting, washing, dewatering, cooling or drying.

The following pages detail standard pan size and capacity information. Other pan sizes and shapes are available. CoilWeb® series vibrating conveyors can be custom-designed for your application.

MATERIAL

CoilWeb® series vibrating conveyors incorporate fabricated steel pans, a natural frequency spring system, a semipositive eccentric drive powered by an electric motor and v-belts on a fabricated steel base.

ASSEMBLY

Standard drive and extension sections are delivered in preassembled sections. Standard welded pan joints or jig-fixtured, bolted pan flanges are available for joining the sections together.

APPLICATION

CoilWeb® series vibrating conveyors are used where horizontal or shallow incline conveying is required. They handle a wide variety of bulk materials, from powders to solids. They are designed to handle fragile, sharp and irregularly shaped materials and are primarily used in the forest products, stamping, food, grain, foundry and die cast industries.

COPYRIGHT © 2021 WEBSTER INDUSTRIES, TIFFIN, OHIO

All rights reserved. No part of this catalog shall be reproduced, stored in a retrieval system, or transmitted by any means, electronic, mechanical, photocopying, recording, or otherwise, without written permission from the publisher. No patent liability is assumed with respect to use of the information contained herein. Although every precaution has been taken in the preparation of this catalog, Webster Industries assumes no responsibility for errors or omissions. Nor is any liability assumed for damages resulting from the use of the information contained herein. Content of this catalog can be changed without any notification by Webster Industries. Please consult with your Inside Sales Representative for confirmation of dimensions and design criteria.



THE WEBSTER VALUE

For over 145 years, Webster has provided conveying solutions to a diverse range of markets with our extensive variety of products and industry expertise. A key to our success is making a difference through industry, work, self, family and community.



AMERICAN MATERIALS, AMERICAN LABOR & AMERICAN PRIDE

Webster's reputation for high-quality products originates from the same principles they were founded on in 1876. Our Made in the USA brand is demonstrated through our domestic supply chain partners and our American workforce.



VERTICALLY INTEGRATED MANUFACTURING FACILITY

While companies are relying increasingly on outsourcing for production needs, Webster has invested in building, maintaining and growing a vertically integrated manufacturing system.

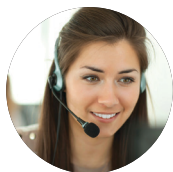

WORLD CLASS CUSTOMER SUPPORT & DELIVERIES

Providing value to customers is Webster's top priority. Our commitment and responsiveness to customers, industry best deliveries and our engineered solutions are what set us apart from the competition.



SUPERIOR QUALITY & INNOVATION

Webster's strict manufacturing, ISO quality standards and continuous innovation ensure that we are providing our customers with the highest quality products in the industry.

AN EMPLOYEE-OWNED COMPANY